

Your partner for Self-lubricating

Bearing Application

# viiplus

## PRODUCTS PROGRAMME

### 产品介绍



# 公司介绍

## COMPANY OVERVIEW

VIIPPLUS是一家制造和销售无油轴承、自润滑轴承、滑动轴承和滑板的专业企业。我们一直依靠成熟的技术，先进的设备，完善的工艺和检验手段，生产出适合于各种工况条件下的无油轴承、自润滑轴承、滑动轴承，产品主要有：VSB-10系列无油干式轴承，VSB-80系列双金属轴承，VSB-50系列固体镶嵌自润滑轴承，VSB-22系列青铜轴承等，被广泛应用于汽车、行业、机械、水利机械、塑胶机械、自动化生产线、印刷包装机械等需要传动而无法加油或较难形成油膜的部位。产品深受国内外客户好评。VIIPPLUS企业将提供顾客最好的产品、合理的价位和完善的售后服务。

VIIPPLUS is a professional design, made and sales self-lubricating bearing company. we are always depend on mature technic, advanced equipment, perfect art and inspectartifice, manufacture the self-lubricating bearing suit for kinds of operating condition. the products: VSB-10 oilless bearing, VSB-80 bimetal bearing, VSB-50 solid lubricant embedded bearing, VSB-22 bronze bearing, etc. It is widely applied to bus industry, buliding engineering machine, water conservancy machine, plastic machine printing packing machine and need drive or without oil or with little oil form lubrication. The product is deeply subjected to domestic and international customer's good opinion! VIIPPLUS company will provide the best product, in reason price and flawless service to customers.

# 无油滑动轴承

## OILLESS BEARING



### 目录 Index

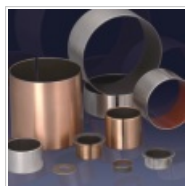

VSB-10 系列  
无油润滑轴承  
OILLESS BEARING

1~9 Page



VSB-50 系列  
固体润滑轴承  
SOLID-LUBRICANT-INLAID  
BEARING

22~28 Page



VSB-20 系列  
边界润滑轴承  
BOUNDARY LUBRICATING  
BEARING

10~14 Page



VSB-22 系列  
青铜卷制轴承  
BRONZE WRAPPED BEARING

29~33 Page



VSB-80 系列  
双金属轴承  
BIMETAL BEARING

15~21 Page



技术支持  
TECHNICAL SUPPORT

34~36 Page

# VSB10系列

## 无油润滑轴承

### OILLESS BEARING



- PTFE和亲油性纤维的混合物在运动时可形成很好的转移膜保护对磨轴。  
PTFE with lipophilicity fiber form a transfer films when operating, which can protect the shaft well .
- 耐磨性能好，磨擦系数低，使用寿命长。  
With low friction coefficient,good anti-wear property make the working life longer.
- 走合性能好，无咬轴现象。  
Good running in property.
- 可运用于旋转、摇摆、往复运动之中。  
It fits well in motion of rotation,sway,reciprocating.
- 无油润滑或少油润滑，减少保养或不保养。  
Dry or with less grease,maintenance free.

# VSB10

## 碳钢基无油润滑轴承

### CARBON-BASED NON-OIL LUBRICATED BEARINGS

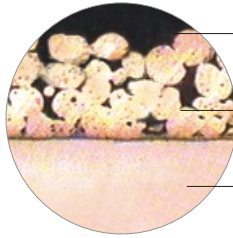
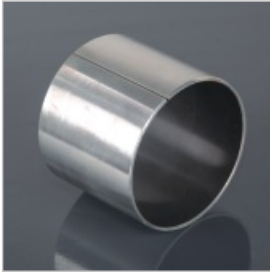

聚四氟乙烯耐磨层  
PTFE Lining 0.01~ 0.03mm

多孔烧结铜粉层  
Porous Bronze Powder 0.20~ 0.30mm

低碳钢  
Low Carbon Steel

### 结构特性及用途

#### Structure Characteristics and Applications

VSB10自润滑复合轴承，剖面结构（见上图）：钢背提供机械强度和承载能力，中间烧结球形多孔青铜粉，与表面聚合物（PTFE+ Pb）牢固嵌合。它充分发挥了金属和聚合物的优点，具有低摩擦系数、良好的耐磨性和自润滑性能。钢背表面镀层防腐蚀，广泛应用于印刷机械、纺织机械烟草机械、健身器、减振器等。

VSB10 (see the above profile picture) is backed with copper-plated steel with porous bronze sintered on the steel and polymers imbedded into the bores of the bronze. The steel back provides the bush made by VSB10 with stronger mechanic strength and load capability. By combining the metals and the polymers together, its products are endowed with the lower friction coefficient and good capacity of anti-abrasion and self-lubrication. Moreover, the steel back is plated with a erosion-prevention layer. Products of VSB10 series are widely applied in printing, weaving and tobacco producing machines, gymnastic equipments, rock absorbers, etc.

### 物理机械性能

#### Physical and Mechanical Performance

性能指标 Performance Index		有关数据 Data	性能指标 Performance Index		有关数据 Data
最大承载压力P Max Load	静载 Static Load	250 N/ mm <sup>2</sup>	摩擦系数 μ Friction Coefficient	脂润滑 Grease Lubrication	0.08~ 0.20
	动载 Dynamic Load	140 N/ mm <sup>2</sup>		油润滑 Oil Lubrication	0.02~ 0.07
最大线速度V Linear Velocity	振动 Oscillation Load	60 N/ mm <sup>2</sup>	相配轴 Mating Axis	硬度 Hardness	> 120 HB
	脂润滑 Grease Lubrication	2.5 m/ s		粗糙度 Roughness	Ra= 0.4~ 1.25
最高PV值 Max PV value	油润滑 Oil Lubrication	5m/ s	工作温度 Working Temperature		-200~ + 280 °C
	脂润滑 Grease Lubrication	3.6 N/ mm <sup>2</sup> .m/ s	导热系数 Heat-conducting Coefficient		40 W/ (m· k)
	油润滑 Oil Lubrication	50 N/ mm <sup>2</sup> .m/ s	热膨胀系数(轴向) Heat-expansion Coefficient(Axial)		11× 10 <sup>-6</sup> K <sup>-1</sup>

# VSB11

## 铜基无油润滑轴承

### COPPER-BASED NON-OIL LUBRICATED BEARINGS

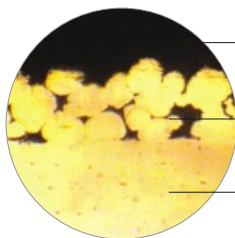

聚四氟乙烯耐磨层  
PTFE Lining 0.01~ 0.03mm

多孔烧结铜粉层  
Porous Bronze Powder 0.20~ 0.30mm

青铜层  
Bronze

### 结构特性及用途

#### Structure Characteristics and Applications

VSB11自润滑复合材料轴承，剖面结构（见右上图）：锡青铜背提供机械强度和承载能力，中间烧结球形多孔青铜粉，与表面聚合物（PTFE+ Pb）牢固嵌合。它充分发挥了金属和聚合物的优点，具有低摩擦系数、良好的耐磨性和自润滑性能。锡青铜背热传导性好，广泛应用于冶金机械、连铸机械、水泥机械和螺旋式输送机。

VSB11 (see the above profile picture) is backed with tin-bronze with porous bronze sintered on it and polymers imbedded into the bores of the bronze. The tin-bronze back provides the products with stronger mechanic strength and load capability. By combining the metals and the polymers together, its products are endowed with the lower friction coefficient and good capacity of anti-abrasion and self-lubrication. Moreover, the tin-bronze back is of good heat conducting capability. Products of VSB11 series are widely applied in metallurgy machine and casting machines, consecutive casting machines, cemetery machines, spiral transporting machines, etc.

### 物理机械性能

#### Physical and Mechanical Performance

性能指标 Performance Index		有关数据 Data	性能指标 Performance Index		有关数据 Data
最大承载压力P Max Load	静载 Static Load	250 N/ mm <sup>2</sup>	摩擦系数 $\mu$ Friction Coefficient	脂润滑 Grease Lubrication	0.08~ 0.20
	动载 Dynamic Load	140 N/ mm <sup>2</sup>		油润滑 Oil Lubrication	0.02~ 0.07
最大线速度V Linear Velocity	振动 Oscillation Load	60 N/ mm <sup>2</sup>	相配轴 Mating Axis	硬度 Hardness	> 120 HB
	脂润滑 Grease Lubrication	2.5 m/ s		粗糙度 Roughness	Ra= 0.4~ 1.25
最高PV值 Max PV value	油润滑 Oil Lubrication	5m/ s	工作温度 Working Temperature		-200~ + 280 °C
	脂润滑 Grease Lubrication	3.6 N/ mm <sup>2</sup> .m/ s	导热系数 Heat-conducting Coefficient		60 W/ (m · k)
	油润滑 Oil Lubrication	50 N/ mm <sup>2</sup> .m/ s	热膨胀系数(轴向) Heat-expansion Coefficient(Axial)		$18 \times 10^{-6} K^{-1}$

# VSB40

## 碳钢基无油润滑轴承

### CARBON-BASED NON-OIL LUBRICATED BEARINGS

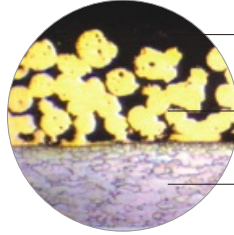

聚四氟乙烯耐磨层  
PTFE Lining 0.01~ 0.03mm

多孔烧结铜粉层  
Porous Bronze Powder 0.20~ 0.30mm

低碳钢  
Low Carbon Steel

### 结构特性及用途

#### Structure Characteristics and Applications

VSB40自润滑复合材料轴承，剖面结构（见右上图）：钢背提供机械强度和承载能力，中间烧结球形多孔青铜粉，与表面聚合物（PTFE+填充材料）牢固嵌合。充分发挥了金属和聚合物的优点，它具有低摩擦系数、良好的耐磨性和自润滑性能。由于不含铅，使轴承润滑条件更干净，符合环保要求，广泛应用于印刷机械、纺织机械烟草机械、健身器、减振器等。

VSB40 (see the above profile picture) is backed with copper-plated steel with porous bronze sintered on the steel and polymers imbedded into the bores of the bronze. The steel back provides the products made by VSB40 with stronger mechanic strength and load capability. By combining the metals and the polymers together, its products are endowed with the lower friction coefficient and good capacity of anti-abrasion and self-lubrication. Moreover, it is a lead-free and environment protection product. Products of VSB40 series are widely applied in printing, weaving and tobacco producing machines, gymnastic equipments, shock absorbers, etc.

### 物理机械性能

#### Physical and Mechanical Performance

性能指标 Performance Index		有关数据 Data	性能指标 Performance Index		有关数据 Data
最大承载压力P Max Load	静载 Static Load	250 N/ mm <sup>2</sup>	摩擦系数 μ Friction Coefficient	脂润滑 Grease Lubrication	0.08~ 0.22
	动载 Dynamic Load	140 N/ mm <sup>2</sup>		油润滑 Oil Lubrication	0.02~ 0.07
最大线速度V Linear Velocity	振动 Oscillation Load	60 N/ mm <sup>2</sup>	相配轴 Mating Axis	硬度 Hardness	> 120 HB
	脂润滑 Grease Lubrication	2 m/ s		粗糙度 Roughness	Ra= 0.4~ 1.25
最高PV值 Max PV value	油润滑 Oil Lubrication	5 m/ s	工作温度 Working Temperature		-200~ + 280 °C
	脂润滑 Grease Lubrication	3.6 N/ mm <sup>2</sup> .m/ s	导热系数 Heat-conducting Coefficient		40 W/ (m· k)
	油润滑 Oil Lubrication	50 N/ mm <sup>2</sup> .m/ s	热膨胀系数(轴向) Heat-expansion Coefficient(Axial)		11 × 10 <sup>-6</sup> K <sup>-1</sup>

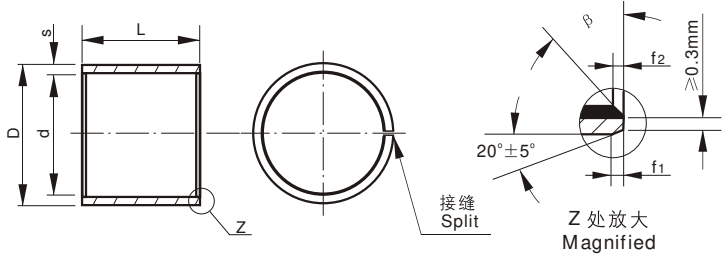
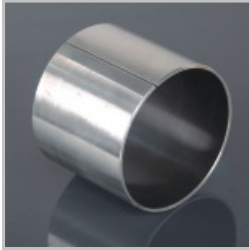

内外倒角

S	f1	f2	$\beta$	S	f1	f2	$\beta$
1.00	0.6±0.3	0.3±0.2	30°±5°	2.00	1.2±0.3	0.5±0.2	30°±5°
1.50	0.7±0.3	0.5±0.2	30°±5°	2.50	1.8±0.3	0.6±0.2	45°±5°

mm

轴径 Shaft Dia.	座孔 Housing Bore H7	外径公差 O.D. Tolerance D	压装后 内孔公差 I.D. after fixed d	配合间隙 Clearance	壁厚 Wall Thickness	L <sup>0</sup> <sub>-0.40</sub> (d ≤ φ28 L-0.3) (d > φ30 L-0.4)														
						6	8	10	12	15	20	25	30	40	50					
6	-0.013 -0.028	8 + 0.015	8 + 0.055 +0.025	5.990 6.055	0.077 0.000	0606	0608	0610												
8	-0.013 -0.028	10 + 0.015	10 + 0.055 +0.025	7.990 8.055	0.083 0.003	0806	0808	0810	0812	0815										
10	-0.016 -0.034	12 + 0.018	12 + 0.065 +0.030	9.990 10.058	0.086 0.003	1006	1008	1010	1012	1015	1020									
12	-0.016 -0.034	14 + 0.018	14 + 0.065 +0.030	11.990 12.058		1206	1208	1210	1212	1215	1220	1225								
13	-0.016 -0.034	15 + 0.018	15 + 0.065 +0.030	12.990 13.058	1.005 0.980			1310			1320									
14	-0.016 -0.034	16 + 0.018	16 + 0.065 +0.030	13.990 14.058	0.092 0.006			1410	1412	1415	1420	1425								
15	-0.016 -0.034	17 + 0.018	17 + 0.065 +0.030	14.990 15.058				1510	1512	1515	1520	1525								
16	-0.016 -0.034	18 + 0.018	18 + 0.065 +0.030	15.990 16.058				1610	1612	1615	1620	1625								
17	-0.016 -0.034	19 + 0.021	19 + 0.075 +0.035	16.990 17.061	0.095 0.006			1710	1712		1720									
18	-0.016 -0.034	20 + 0.021	20 + 0.075 +0.035	17.990 18.061				1810	1812	1815	1820	1825								
20	-0.020 -0.041	23 + 0.021	23 + 0.075 +0.035	19.990 20.071				2010	2012	2015	2020	2025								
22	-0.020 -0.041	25 + 0.021	25 + 0.075 +0.035	21.990 22.071	0.112 0.010			2210	2212	2215	2220	2225								
24	-0.020 -0.041	27 + 0.021	27 + 0.075 +0.035	23.990 24.071						2415	2420	2425	2430							
25	-0.020 -0.041	28 + 0.021	28 + 0.075 +0.035	24.990 25.071				2510	2512	2515	2520	2525	2530	2540	2550					
28	-0.020 -0.041	32 + 0.025	32 + 0.085 +0.045	27.990 28.085	0.116 0.010					2815	2820	2825	2830	2840						
30	-0.020 -0.041	34 + 0.025	34 + 0.085 +0.045	29.990 30.085				3012	3015	3020	3025	3030	3040							
32	-0.025 -0.050	36 + 0.025	36 + 0.085 +0.045	31.990 32.085							3220	3225	3230	3240						
35	-0.025 -0.050	39 + 0.025	39 + 0.085 +0.045	34.990 35.085	0.135 0.015					3512	3515	3520	3525	3530	3540	3550				
38	-0.025 -0.050	42 + 0.025	42 + 0.085 +0.045	37.990 38.085						3815		3825	3830	3840						
40	-0.025 -0.050	44 + 0.025	44 + 0.085 +0.045	39.990 40.085						4012		4020	4025	4030	4040	4050				



mm

轴径 Shaft Dia.	座孔 Housing Bore H7	外径公差 O.D. Tolerance D	压装后 内孔公差 I.D.after fixed d	配合间隙	壁厚 Wall Thickness	L <sup>0</sup> <sub>-0.40</sub> (d≤Φ28 L-0.3) (d>Φ30 L-0.4)									
						20	25	30	40	50	60	70	80	100	
45 <sup>-0.025</sup> <sub>-0.050</sub>	50 <sup>+0.025</sup>	50 <sup>+0.085</sup> <sub>+0.045</sub>	44.990 45.105	0.155 0.015		4520	4525	4530	4540	4550					
50 <sup>-0.030</sup> <sub>-0.060</sub>	55 <sup>+0.030</sup>	55 <sup>+0.100</sup> <sub>+0.055</sub>	49.990 50.110	0.160 0.015		5020		5030	5040	5050	5060				
55 <sup>-0.030</sup> <sub>-0.060</sub>	60 <sup>+0.030</sup>	60 <sup>+0.100</sup> <sub>+0.055</sub>	54.990 55.110					5530	5540	5550	5560				
60 <sup>-0.030</sup> <sub>-0.060</sub>	65 <sup>+0.030</sup>	65 <sup>+0.100</sup> <sub>+0.055</sub>	59.990 60.110		2.505 2.460			6030	6040	6050	6060	6070			
65 <sup>-0.030</sup> <sub>-0.060</sub>	70 <sup>+0.030</sup>	70 <sup>+0.100</sup> <sub>+0.055</sub>	64.990 65.110	0.170 0.020				6530	6540	6550	6560	6570			
70 <sup>-0.030</sup> <sub>-0.060</sub>	75 <sup>+0.030</sup>	75 <sup>+0.100</sup> <sub>+0.055</sub>	69.990 70.110						7040	7050	7060	7070	7080		
75 <sup>-0.030</sup> <sub>-0.060</sub>	80 <sup>+0.030</sup>	80 <sup>+0.100</sup> <sub>+0.055</sub>	74.990 75.110					7530	7540	7550	7560	7570	7580		
80 <sup>-0.035</sup>	85 <sup>+0.035</sup>	85 <sup>+0.120</sup> <sub>+0.070</sub>	80.020 80.155	0.201 0.020					8040	8050	8060	8070	8080	80100	
85 <sup>-0.035</sup>	90 <sup>+0.035</sup>	90 <sup>+0.120</sup> <sub>+0.070</sub>	85.020 85.155						8540				8580	85100	
90 <sup>-0.035</sup>	95 <sup>+0.035</sup>	95 <sup>+0.120</sup> <sub>+0.070</sub>	90.020 90.155						9040	9050	9060		9080	90100	
95 <sup>-0.035</sup>	100 <sup>+0.035</sup>	100 <sup>+0.120</sup> <sub>+0.070</sub>	95.020 95.155		2.490 2.440					9550	9560		9580	95100	
100 <sup>-0.035</sup>	105 <sup>+0.035</sup>	105 <sup>+0.120</sup> <sub>+0.070</sub>	100.020 100.155	0.209 0.020						10050	10060		10080		
105 <sup>-0.035</sup>	110 <sup>+0.035</sup>	110 <sup>+0.120</sup> <sub>+0.070</sub>	105.020 105.155								10560		10580		
110 <sup>-0.035</sup>	115 <sup>+0.035</sup>	115 <sup>+0.120</sup> <sub>+0.070</sub>	110.020 110.155								11060		11080		
120 <sup>-0.04</sup>	125 <sup>+0.035</sup>	125 <sup>+0.120</sup> <sub>+0.070</sub>	120.070 120.210	0.264 0.070							12060		12080		
125 <sup>-0.04</sup>	130 <sup>+0.04</sup>	130 <sup>+0.170</sup> <sub>+0.100</sub>	125.070 125.210								12560		12580	125100	
130 <sup>-0.04</sup>	135 <sup>+0.04</sup>	135 <sup>+0.170</sup> <sub>+0.100</sub>	130.070 130.210								13060			130100	
140 <sup>-0.04</sup>	145 <sup>+0.04</sup>	145 <sup>+0.170</sup> <sub>+0.100</sub>	140.070 140.210	0.273 0.070							14060		14080	140100	
150 <sup>-0.04</sup>	155 <sup>+0.04</sup>	155 <sup>+0.170</sup> <sub>+0.100</sub>	150.070 150.210								15050	15060		15080	150100
160 <sup>-0.04</sup>	165 <sup>+0.04</sup>	165 <sup>+0.170</sup> <sub>+0.100</sub>	160.070 160.210								16060		16080	160100	
180 <sup>-0.046</sup>	185 <sup>+0.046</sup>	185 <sup>+0.210</sup> <sub>+0.130</sub>	180.070 180.216	0.279 0.070	2.465 2.415								18080	180100	
190 <sup>-0.046</sup>	195 <sup>+0.046</sup>	195 <sup>+0.210</sup> <sub>+0.130</sub>	190.070 190.216										19080	190100	
200 <sup>-0.046</sup>	205 <sup>+0.046</sup>	205 <sup>+0.210</sup> <sub>+0.130</sub>	200.070 200.216	0.288 0.070							20060		20080	200100	
220 <sup>-0.046</sup>	225 <sup>+0.046</sup>	225 <sup>+0.210</sup> <sub>+0.130</sub>	220.070 220.216										22080	220100	
250 <sup>-0.052</sup>	255 <sup>+0.052</sup>	255 <sup>+0.260</sup> <sub>+0.170</sub>	250.070 250.222	0.294 0.070									25080	250100	
260 <sup>-0.052</sup>	265 <sup>+0.052</sup>	265 <sup>+0.260</sup> <sub>+0.170</sub>	260.070 260.222										26080	260100	
280 <sup>-0.052</sup>	285 <sup>+0.052</sup>	285 <sup>+0.260</sup> <sub>+0.170</sub>	280.070 280.222	0.303 0.070									28080	280100	
300 <sup>-0.052</sup>	305 <sup>+0.052</sup>	305 <sup>+0.260</sup> <sub>+0.170</sub>	300.070 300.222										30080	300100	

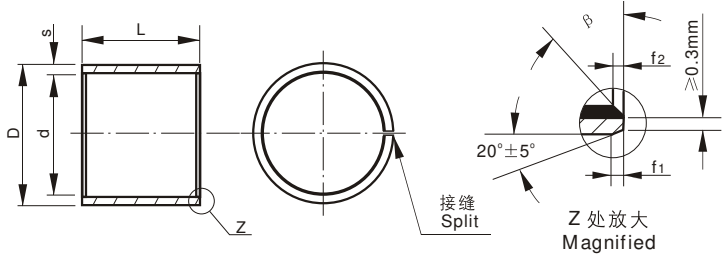
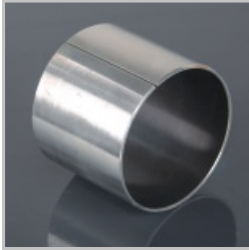

内外倒角

S	f <sub>1</sub>	f <sub>2</sub>	β	S	f <sub>1</sub>	f <sub>2</sub>	β
1.00	0.6±0.3	0.3±0.2	30°±5°	2.00	1.2±0.3	0.5±0.2	30°±5°
1.50	0.7±0.3	0.5±0.2	30°±5°	2.50	1.8±0.3	0.6±0.2	45°±5°

mm

轴径 Shaft Dia.	座孔 Housing Bore H7	外径公差 O.D. Tolerance D	压装后 内孔公差 I.D. after fixed d	配合间隙 Clearance	壁厚 Wall Thickness	L <sup>0</sup> (d ≤ φ28 L-0.3) -0.40 (d > φ30 L-0.4)														
						6	8	10	12	15	20	25	30	40	50					
6	-0.013 -0.028	8 + 0.015	8 + 0.055 +0.025	5.990 6.055	0.077 0.000	0606	0608	0610												
8	-0.013 -0.028	10 + 0.015	10 + 0.055 +0.025	7.990 8.055	0.083 0.003	0806	0808	0810	0812	0815										
10	-0.016 -0.034	12 + 0.018	12 + 0.065 +0.030	9.990 10.058	0.086 0.003	1006	1008	1010	1012	1015	1020									
12	-0.016 -0.034	14 + 0.018	14 + 0.065 +0.030	11.990 12.058		1206	1208	1210	1212	1215	1220	1225								
13	-0.016 -0.034	15 + 0.018	15 + 0.065 +0.030	12.990 13.058	1.005 0.980			1310			1320									
14	-0.016 -0.034	16 + 0.018	16 + 0.065 +0.030	13.990 14.058	0.092 0.006			1410	1412	1415	1420	1425								
15	-0.016 -0.034	17 + 0.018	17 + 0.065 +0.030	14.990 15.058				1510	1512	1515	1520	1525								
16	-0.016 -0.034	18 + 0.018	18 + 0.065 +0.030	15.990 16.058				1610	1612	1615	1620	1625								
17	-0.016 -0.034	19 + 0.021	19 + 0.075 +0.035	16.990 17.061	0.095 0.006			1710	1712		1720									
18	-0.016 -0.034	20 + 0.021	20 + 0.075 +0.035	17.990 18.061				1810	1812	1815	1820	1825								
20	-0.020 -0.041	23 + 0.021	23 + 0.075 +0.035	19.990 20.071				2010	2012	2015	2020	2025								
22	-0.020 -0.041	25 + 0.021	25 + 0.075 +0.035	21.990 22.071	0.112 0.010			2210	2212	2215	2220	2225								
24	-0.020 -0.041	27 + 0.021	27 + 0.075 +0.035	23.990 24.071						2415	2420	2425	2430							
25	-0.020 -0.041	28 + 0.021	28 + 0.075 +0.035	24.990 25.071				2510	2512	2515	2520	2525	2530	2540	2550					
28	-0.020 -0.041	32 + 0.025	32 + 0.085 +0.045	27.990 28.085	0.116 0.010					2815	2820	2825	2830	2840						
30	-0.020 -0.041	34 + 0.025	34 + 0.085 +0.045	29.990 30.085				3012	3015	3020	3025	3030	3040							
32	-0.025 -0.050	36 + 0.025	36 + 0.085 +0.045	31.990 32.085						3220	3225	3230	3240							
35	-0.025 -0.050	39 + 0.025	39 + 0.085 +0.045	34.990 35.085	0.135 0.015					3512	3515	3520	3525	3530	3540	3550				
38	-0.025 -0.050	42 + 0.025	42 + 0.085 +0.045	37.990 38.085						3815		3825	3830	3840						
40	-0.025 -0.050	44 + 0.025	44 + 0.085 +0.045	39.990 40.085						4012		4020	4025	4030	4040	4050				

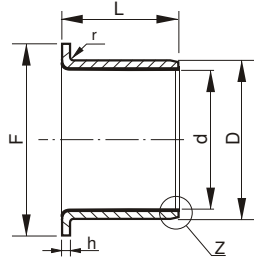

h	1.0	1.5	2.0	2.5
r	1 <sup>-0.5</sup>	1±0.5	1.5±0.5	2±0.5

端面倒角参照直套

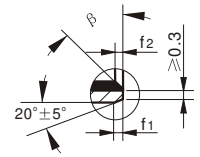
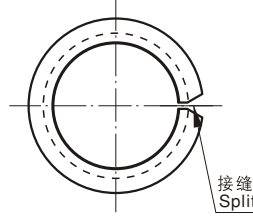

Z 处放大  
Magnified

mm

规格型号 Type	轴径 Shaft Dia.	座孔 Housing H7	外径公差 O.D. Tolerance D	压装后 内孔公差 I.D.after fixed d	配合间隙 Clearance	壁厚 Wall Thickness	法兰尺寸 Size Of Washer				
							d	D	F ±0.50	L ±0.25	h -0.2
VS B10F 06040	6 <sup>-0.010</sup> -0.022	8 <sup>+</sup> 0.015	8 <sup>+</sup> 0.055 + 0.025	6.055 5.990	0.077 0.000		6	8	12	4	
VS B10F 06070										7	
VS B10F 08055	8 <sup>-0.013</sup> -0.028	10 <sup>+</sup> 0.015	10 <sup>+</sup> 0.055 + 0.025	8.055 7.990	0.083 0.003		8	10	15	5.5	
VS B10F 08075										7.5	
VS B10F 10070	10 <sup>-0.016</sup> -0.034	12 <sup>+</sup> 0.018	12 <sup>+</sup> 0.055 + 0.025	10.058 9.990	0.086 0.003		10	12	18	7	
VS B10F 10090										9	
VS B10F 10120										12	
VS B10F 12070										7	
VS B10F 12090	12 <sup>-0.016</sup> -0.034	14 <sup>+</sup> 0.018	14 <sup>+</sup> 0.065 + 0.030	12.058 11.990		1.005 0.980	12	14	20	9	1
VS B10F 12120										12	
VS B10F 14120	14 <sup>-0.016</sup> -0.034	16 <sup>+</sup> 0.018	16 <sup>+</sup> 0.065 + 0.030	14.058 13.990			14	16	22	12	
VS B10F 14170										17	
VS B10F 15090	15 <sup>-0.016</sup> -0.034	17 <sup>+</sup> 0.018	17 <sup>+</sup> 0.065 + 0.030	15.058 14.990	0.092 0.006					9	
VS B10F 15120										12	
VS B10F 15170										17	
VS B10F 16120										12	
VS B10F 16170	16 <sup>-0.016</sup> -0.034	18 <sup>+</sup> 0.018	18 <sup>+</sup> 0.065 + 0.030	16.058 15.990			16	18	24	17	
VS B10F 18120										12	
VS B10F 18170	18 <sup>-0.016</sup> -0.034	20 <sup>+</sup> 0.021	20 <sup>+</sup> 0.075 + 0.035	18.061 17.990	0.095 0.006		18	20	26	17	
VS B10F 18200										20	
VS B10F 20115	20 <sup>-0.020</sup> -0.041	23 <sup>+</sup> 0.021	23 <sup>+</sup> 0.075 + 0.035	20.071 19.990						11.5	
VS B10F 20165										16.5	
VS B10F 20215										21.5	
VS B10F 22150										15	
VS B10F 22200	22 <sup>-0.020</sup> -0.041	25 <sup>+</sup> 0.021	25 <sup>+</sup> 0.075 + 0.035	22.071 21.990	0.112 0.010	1.505 1.475	22	25	32	20	1.5
VS B10F 25115										11.5	
VS B10F 25165	25 <sup>-0.020</sup> -0.041	28 <sup>+</sup> 0.021	28 <sup>+</sup> 0.075 + 0.035	25.071 24.990			25	28	35	16.5	
VS B10F 25215										21.5	
VS B10F 30160	30 <sup>-0.025</sup> -0.050	34 <sup>+</sup> 0.025	34 <sup>+</sup> 0.075 + 0.035	30.085 29.990	0.126 0.010		30	34	42	16	
VS B10F 30260										26	
VS B10F 35160	35 <sup>-0.025</sup> -0.050	39 <sup>+</sup> 0.025	39 <sup>+</sup> 0.085 + 0.045	35.085 34.990	0.135 0.015		35	39	47	16	2
VS B10F 35260										26	
VS B10F 40260	40 <sup>-0.025</sup> -0.050	44 <sup>+</sup> 0.025	44 <sup>+</sup> 0.085 + 0.045	40.085 39.990			40	44	53	26	
VS B10F 40400										40	

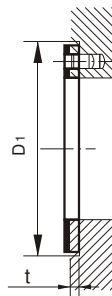
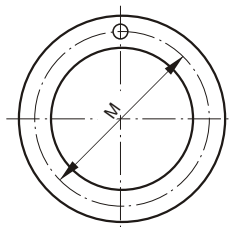
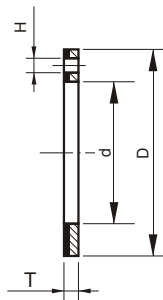

mm

规格型号 Type	轴径 Shaft Dia.	垫片尺寸 Size Of Washer				安装尺寸 Size For Installation		
		$d + 0.25$	$D - 0.25$	$T - 0.05$	$M^{+0.12}_{-0.12}$	$H^{+0.4}_{+0.1}$	t	$D_1$
VSB10 WC 10	8	10	20	1.5	15	1.5	1	20
VSB10 WC 12	10	12	24	1.5	18	1.5	1	24
VSB10 WC 14	12	14	26	1.5	20	2	1	26
VSB10 WC 16	14	16	30	1.5	23	2	1	30
VSB10 WC 18	16	18	32	1.5	25	2	1	32
VSB10 WC 20	18	20	36	1.5	28	3	1	36
VSB10 WC 22	20	22	38	1.5	30	3	1	38
VSB10 WC 24	22	24	42	1.5	33	3	1	42
VSB10 WC 26	24	26	44	1.5	35	3	1	44
VSB10 WC 28	25	28	48	1.5	38	4	1	48
VSB10 WC 32	30	32	54	1.5	43	4	1	54
VSB10 WC 38	35	38	62	1.5	50	4	1	62
VSB10 WC 42	40	42	66	1.5	54	4	1	66
VSB10 WC 48	45	48	74	2	61	4	1.5	74
VSB10 WC 52	50	52	78	2	65	4	1.5	78
VSB10 WC 62	60	62	90	2	76	4	1.5	90

# VSB20系列

## 边界润滑轴承

### BOUNDARY LUBRICATING BEARING



- 承载好，耐磨性能良好。  
Good load and anti-wear capacity
- 适用于高载低速下的旋转运动、摇摆运动及经常在载荷下启闭频繁而不易形成流体动力润滑的场合。  
Fits for the motion of rotation and sway or frequent stop-start with high load and low speed condition.
- 在边界润滑条件下可长期不加油保养，而在过层中加油使轴承使用寿命更长。  
It can work long time without oil in the condition of boundary lubrication, add oil or grease when operating can make it working time longer
- 表面塑料层在加工成型时可留一定的余量，装配压入座孔后可自行加工，以达到更好的装配尺寸。  
It is machinable for the thicker of POM.

# VSB20

## 边界润滑轴承

### BOUNDARY LUBRICATION BEARINGS

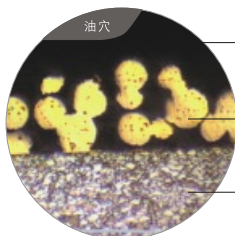
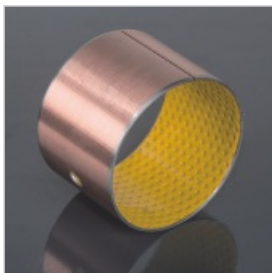

- 1、聚甲醛耐磨层 0.30-0.50m m  
POM Lining 0.3-0.5mm
- 2、多孔烧结铜粉层 0.20-0.35m m  
Porous Bronze Powder 0.20-0.35mm
- 3、低碳钢  
Low Carbon Steel

### 结构特性及用途

#### Structure Characteristics and Applications

VSB20边界润滑复合材料轴承，剖面结构(见右上图)：钢背提供机械强度和承载能力，中间烧结球形青铜粉，与表面改性聚甲醛(POM)牢固嵌合。表面轧制储油坑，从而实现了摩擦副之间的良好润滑。它具有好的耐磨性和承载能力，钢背表面镀层防腐蚀。由于表面改性聚POM不含铅，使轴承润滑条件更干净，符合环保要求，广泛应用于汽车底盘、锻压机床、矿山机械、冶金机械、水利和轧钢行业等。

VSB20 is designed for marginal lubricating bearing. (See the above structural profile.) It is backed with copper-plated steel with porous bronze sintered on it and polymers (POM) imbedded into the bores of the bronze. The steel back provides the products made by VSB20 with stronger mechanic strength and load capability. Oil dents stamped on the surface of the polymer can achieve good lubrication between the bearing and its mating axis. It is of good anti-abrasion and load capability. The plating coating on the surface is erosion protective. And it is environment protective as no lead includes in the surface polymer POM. Products of VSB20 series are widely used on automotive chassis, forging machines, mine quarrying machines, metal melting and casting machines and in water irrigating and steel rolling industries.

### 物理机械性能

#### Physical and Mechanical Performance

性能指标 Performance Index		有关数据 Data	性能指标 Performance Index		有关数据 Data
最大承载压力P Max Load	静载 Static Load	250 N/ mm <sup>2</sup>	摩擦系数 μ Friction Coefficient	脂润滑 Grease Lubrication	0.15~ 0.25
	动载 Dynamic Load	140 N/ mm <sup>2</sup>		油润滑 Oil Lubrication	0.05~ 0.15
最大线速度V Linear Velocity	振动 Oscillation Load	70 N/ mm <sup>2</sup>	相配轴 Mating Axis	硬度 Hardness	> 270 HB
	脂润滑 Grease Lubrication	2.5 m/ s		粗糙度 Roughness	Ra= 0.4~ 1.25
最高PV值 Max PV value	油润滑 Oil Lubrication	> 3 m/ s	工作温度 Working Temperature		-40~ + 120 °C
	脂润滑 Grease Lubrication	2.8 N/ mm <sup>2</sup> .m/ s	导热系数 Heat-conducting Coefficient		52 W/ (m· k)
	油润滑 Oil Lubrication	50 N/ mm <sup>2</sup> .m/ s	热膨胀系数(轴向) Heat-expansion Coefficient (Axial)		11 × 10 <sup>-6</sup> K <sup>-1</sup>

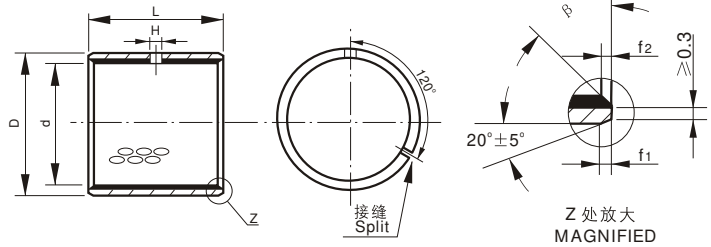

内外倒角

S	f1	f2	β	S	f1	f2	β
1.00	0.6±0.3	0.3±0.2	30°±5°	2.00	1.2±0.3	0.5±0.2	30°±5°
1.50	0.7±0.3	0.5±0.2	30°±5°	2.50	1.8±0.3	0.6±0.2	45°±5°

mm

轴径 Shaft Dia.	座孔 Housing Bore H7	外径公差 O.D. Tolerance D	压装后 内孔公差 I.D. after fixed d	配合间隙 Clearance	壁厚 Wall Thickness	油孔 Hole Dia.	L <sup>0</sup> <sub>-0.40</sub>											
							10	15	20	25	30	35	40	45	50			
10 <sup>-0.022</sup>	12 <sup>+0.018</sup>	12 <sup>+0.065</sup> <sub>+0.030</sub>	10.108 10.040	0.130 0.040			1010	1015	1020									
12 <sup>-0.027</sup>	14 <sup>+0.018</sup>	14 <sup>+0.065</sup> <sub>+0.030</sub>	12.108 12.040				1210	1215	1220									
14 <sup>-0.027</sup>	16 <sup>+0.018</sup>	16 <sup>+0.065</sup> <sub>+0.030</sub>	14.108 14.040	0.135 0.040	0.980 0.955	4		1415	1420									
15 <sup>-0.027</sup>	17 <sup>+0.018</sup>	17 <sup>+0.065</sup> <sub>+0.030</sub>	15.108 15.040				1515	1520	1525									
16 <sup>-0.027</sup>	18 <sup>+0.018</sup>	18 <sup>+0.065</sup> <sub>+0.030</sub>	16.108 16.040				1615	1620	1625									
18 <sup>-0.027</sup>	20 <sup>+0.021</sup>	20 <sup>+0.075</sup> <sub>+0.035</sub>	18.111 18.040	0.138 0.040			1815	1820	1825									
20 <sup>-0.033</sup>	23 <sup>+0.021</sup>	23 <sup>+0.075</sup> <sub>+0.035</sub>	20.131 20.050				2015	2020	2025	2030								
22 <sup>-0.033</sup>	25 <sup>+0.021</sup>	25 <sup>+0.075</sup> <sub>+0.035</sub>	22.131 22.050	0.164 0.050	1.475 1.445		2215		2225									
25 <sup>-0.033</sup>	28 <sup>+0.021</sup>	28 <sup>+0.075</sup> <sub>+0.035</sub>	25.131 25.050					2520	2525	2530								
28 <sup>-0.033</sup>	32 <sup>+0.025</sup>	32 <sup>+0.085</sup> <sub>+0.045</sub>	28.155 28.060	0.188 0.060		6		2820		2830								
30 <sup>-0.033</sup>	34 <sup>+0.025</sup>	34 <sup>+0.085</sup> <sub>+0.045</sub>	30.155 30.060		1.970 1.935		3020	3025	3030		3040							
35 <sup>-0.039</sup>	39 <sup>+0.025</sup>	39 <sup>+0.085</sup> <sub>+0.045</sub>	35.155 35.060	0.194 0.060			3520		3530	3535	3540							
40 <sup>-0.039</sup>	44 <sup>+0.025</sup>	44 <sup>+0.085</sup> <sub>+0.045</sub>	40.155 40.060				4020		4030		4040						4050	
45 <sup>-0.039</sup>	50 <sup>+0.025</sup>	50 <sup>+0.085</sup> <sub>+0.045</sub>	45.195 45.080	0.234 0.080			4520		4530		4540	4545	4550					
50 <sup>-0.039</sup>	55 <sup>+0.030</sup>	55 <sup>+0.100</sup> <sub>+0.055</sub>	50.200 50.080	0.239 0.080	2.460 2.415	8			5030		5040						5050	
55 <sup>-0.046</sup>	60 <sup>+0.030</sup>	60 <sup>+0.100</sup> <sub>+0.055</sub>	55.200 55.080	0.246 0.080			5530		5540		5550							
60 <sup>-0.046</sup>	65 <sup>+0.030</sup>	65 <sup>+0.100</sup> <sub>+0.055</sub>	60.200 60.080				6030		6040		6050							

mm

轴径 Shaft Dia.	座孔 Housing Bore H7	外径公差 O.D. Tolerance D	压装后 内孔公差 I.D. after fixed d	配合间隙 Clearance	壁厚 Wall Thickness	油孔 Hole Dia.	L <sup>0</sup> <sub>-0.40</sub>										
							40	50	60	65	80	90	95	100			
65 <sub>-0.046</sub>	70 <sup>+0.030</sup>	70 <sup>+0.100</sup> <sub>+0.055</sub>	65.200 65.080				6540		6560								
70 <sub>-0.046</sub>	75 <sup>+0.030</sup>	75 <sup>+0.100</sup> <sub>+0.055</sub>	70.200 70.080	0.246 0.080	2.460 2.415	8	7040	7050		7065	7080						
75 <sub>-0.046</sub>	80 <sup>+0.030</sup>	80 <sup>+0.100</sup> <sub>+0.055</sub>	75.200 75.080				7540		7560		7580						
80 <sub>-0.046</sub>	85 <sup>+0.035</sup>	85 <sup>+0.120</sup> <sub>+0.070</sub>	80.265 80.100	0.311 0.100			8040		8060		8080						
85 <sub>-0.054</sub>	90 <sup>+0.035</sup>	90 <sup>+0.120</sup> <sub>+0.070</sub>	85.265 85.100				8540		8560		8580						
90 <sub>-0.054</sub>	95 <sup>+0.035</sup>	95 <sup>+0.120</sup> <sub>+0.070</sub>	90.265 90.100				9040		9060		9080	9090					
100 <sub>-0.054</sub>	105 <sup>+0.035</sup>	105 <sup>+0.120</sup> <sub>+0.070</sub>	100.265 100.100	0.319 0.100				10050	10060		10080			10095			
105 <sub>-0.054</sub>	110 <sup>+0.035</sup>	110 <sup>+0.120</sup> <sub>+0.070</sub>	105.265 105.100						10560		10580			10595	105100		
110 <sub>-0.054</sub>	115 <sup>+0.035</sup>	115 <sup>+0.120</sup> <sub>+0.070</sub>	110.265 110.100						11060		11080			11095	110100		
120 <sub>-0.054</sub>	125 <sup>+0.040</sup>	125 <sup>+0.170</sup> <sub>+0.100</sub>	120.270 120.110	0.324 0.110					12060		12080						120100
125 <sub>-0.063</sub>	130 <sup>+0.040</sup>	130 <sup>+0.170</sup> <sub>+0.100</sub>	125.270 125.110						12560		12580						125100
130 <sub>-0.063</sub>	135 <sup>+0.040</sup>	135 <sup>+0.170</sup> <sub>+0.100</sub>	130.270 130.110					13050	13060		13080						130100
140 <sub>-0.063</sub>	145 <sup>+0.040</sup>	145 <sup>+0.170</sup> <sub>+0.100</sub>	140.270 140.110	0.333 0.110	2.450 2.385	9.5		14050	14060		14080						140100
150 <sub>-0.063</sub>	155 <sup>+0.040</sup>	155 <sup>+0.170</sup> <sub>+0.100</sub>	150.270 150.110					15050	15060		15080						150100
160 <sub>-0.063</sub>	165 <sup>+0.040</sup>	165 <sup>+0.170</sup> <sub>+0.100</sub>	160.270 160.110					16050	16060		16080						160100
170 <sub>-0.063</sub>	175 <sup>+0.040</sup>	175 <sup>+0.170</sup> <sub>+0.100</sub>	170.270 170.110					17050	17060		17080						170100
180 <sub>-0.063</sub>	185 <sup>+0.046</sup>	185 <sup>+0.210</sup> <sub>+0.130</sub>	180.276 180.110	0.339 0.110				18050	18060		18080						180100
190 <sub>-0.072</sub>	195 <sup>+0.046</sup>	195 <sup>+0.210</sup> <sub>+0.130</sub>	190.276 190.110					19050	19060		19080						190100
200 <sub>-0.072</sub>	205 <sup>+0.046</sup>	205 <sup>+0.210</sup> <sub>+0.130</sub>	200.276 200.110	0.348 0.110				20050	20060		20080						200100
220 <sub>-0.072</sub>	225 <sup>+0.046</sup>	225 <sup>+0.210</sup> <sub>+0.130</sub>	220.276 220.110					22050	22060		22080						220100
240 <sub>-0.072</sub>	245 <sup>+0.046</sup>	245 <sup>+0.210</sup> <sub>+0.130</sub>	240.276 240.110					24050	24060		24080						240100
250 <sub>-0.072</sub>	255 <sup>+0.052</sup>	255 <sup>+0.260</sup> <sub>+0.170</sub>	250.282 250.110	0.354 0.110				25050	25060		25080						250100
260 <sub>-0.081</sub>	265 <sup>+0.052</sup>	265 <sup>+0.260</sup> <sub>+0.170</sub>	260.282 260.110					26050	26060		26080						260100
280 <sub>-0.081</sub>	285 <sup>+0.052</sup>	285 <sup>+0.260</sup> <sub>+0.170</sub>	280.282 280.110	0.363 0.110				28050	28060		28080						280100
300 <sub>-0.081</sub>	305 <sup>+0.052</sup>	305 <sup>+0.260</sup> <sub>+0.170</sub>	300.282 300.110					30050	30060		30080						300100



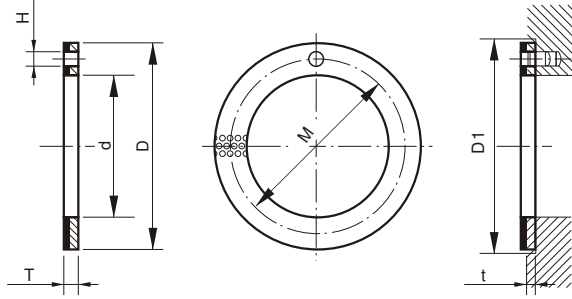
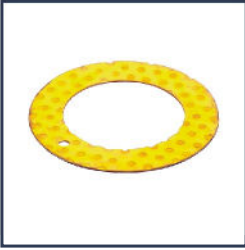

mm

规格型号 Type	轴径 Shaft Dia.	垫片尺寸 Size Of Washer				安装尺寸 Size For Installation		
		$d^{+0.25}$	$D - 0.25$	$T - 0.05$	$M^{+0.12}_{-0.12}$	$H^{+0.4}_{+0.1}$	$t^{+0.2}_{-0.2}$	$D1^{+0.12}$
VSB WC10	8	10	20	1.5	15	1.5	1	20
VSB WC12	10	12	24	1.5	18	1.5	1	24
VSB WC14	12	14	26	1.5	20	2	1	26
VSB WC16	14	16	30	1.5	23	2	1	30
VSB WC18	16	18	32	1.5	25	2	1	32
VSB WC20	18	20	36	1.5	28	3	1	36
VSB WC22	20	22	38	1.5	30	3	1	38
VSB WC24	22	24	42	1.5	33	3	1	42
VSB WC26	24	26	44	1.5	35	3	1	44
VSB WC28	25	28	48	1.5	38	4	1	48
VSB WC32	30	32	54	1.5	43	4	1	54
VSB WC38	35	38	62	1.5	50	4	1	62
VSB WC42	40	42	66	1.5	54	4	1	66
VSB WC48	45	48	74	2	61	4	1.5	74
VSB WC52	50	52	78	2	65	4	1.5	78
VSB WC62	60	62	90	2	76	4	1.5	90

# VSB80 系列

## 双金属轴承

### BIMETAL BEARING



- 它有很高的疲劳强度和承载能力，高的抗冲击力。  
It has high fatigue strength, load capacity and impact strength.
- 良好的抗腐蚀性  
It has good corrosion resistance
- 较好的轴承表面性能  
relatively good surface performance

## VSB 80

钢和铜铅合金粉  
Steel+ lead bronze powder

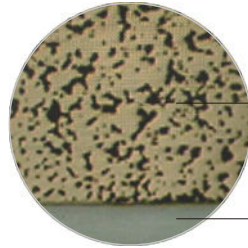

铜铅合金烧结层  
CuSn10Pb Bronze Alloy

低碳钢  
Low Carbon Steel

### 结构特性及用途 Structure Characteristics and Applications

以优质低碳钢为基础，表面烧结铜合金材料，具有很高的承载性，适用于中载高速，以及有大冲击载荷的轴承，轴承表面可加工油穴或者油槽可很好的储油，有效降低磨损，广泛用于卡车底盘、农用机械、工程机械、建筑机械等领域。

Based on high quality low carbon steel, sintering bronze alloy on the surface, provide high specific load, especially fits for high speed and shock conditions. Oil pockets or groove could be processed in the lining in order to well reserve grease. Widely used in truck chassis, agricultural machinery, construction machinery etc.

### 物理机械性能 Physical and Mechanical Performance

性能指标 Performance Index		有关数据 Data	性能指标 Performance Index	有关数据 Data
最大承载压力P Max Load	静承载 Static	250 N/ mm <sup>2</sup>	合金硬度 Alloy Hardness	HB 60~ 100
	动承载 Dynamic	140 N/ mm <sup>2</sup>	使用温度 Temperature	-40℃~ 250℃
最大线速度V Linear Velocity		2.5 m/ s	摩擦系数 Friction Coefficient	0.05~ 0.12
最高PV值 Max PV value		2.8 N/ mm <sup>2</sup> · m/ s	导热系数 Thermal Conductivity	60 W/ ( m · k)
剪切强度 Shear Strength		170 N/ mm <sup>2</sup>	热膨胀系数 Coef. of thermal expansion	14 · 10 <sup>-6</sup> k <sup>-1</sup>

## VSB80

无铅加石墨  
钢+ 无铅铜合金粉  
Steel lead-free bronze powder

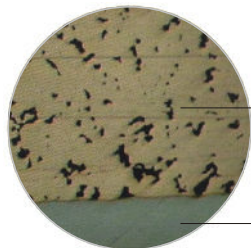

无铅铜合金烧结层  
CuSn8Ni Lead Free Bronze Alloy

低碳钢  
Low Carbon Steel

## 结构特性及用途

## Structure Characteristics and Applications

以优质低碳钢为基础，表面烧结无铅铜合金材料，轴承表面可以加工油穴、油槽，可以很好的存储油脂，有效降低磨损。而无铅又是满足欧盟指定标准，是汽车等领域首选！

Based on high quality low carbon steel, sintering lead-free bronze alloy on the surface. Oil pockets or groove could be processed in the lining in order to well reserve grease. Lead free meet the requirements of EU, it's the best choice of automotive filed.

## 物理机械性能

## Physical and Mechanical Performance

性能指标 Performance Index		有关数据 Data	性能指标 Performance Index	有关数据 Data
最大承载压力P Max Load	静承载 Static	250 N/ mm <sup>2</sup>	合金硬度 Alloy Hardness	HB 60~ 100
	动承载 Dynamic	140 N/ mm <sup>2</sup>	使用温度 Temperature	-40℃~ 250℃
最大线速度V Linear Velocity		2.5 m/ s	摩擦系数 Friction Coefficient	0.05~ 0.12
最高PV值 Max PV value		2.8 N/ mm <sup>2</sup> · m/ s	导热系数 Thermal Conductivity	60 W/ ( m · k)
剪切强度 Shear Strength		170 N/ mm <sup>2</sup>	热膨胀系数 Coef. of thermal expansion	14 · 10 <sup>-6</sup> k <sup>-1</sup>

## VSB 80

钢和无铅铜合金+ 固体润滑剂  
Steel+ lead-free bronze+ solid Inbricant

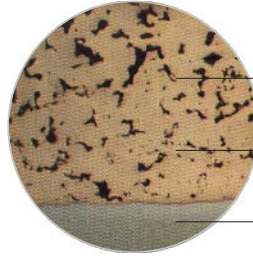
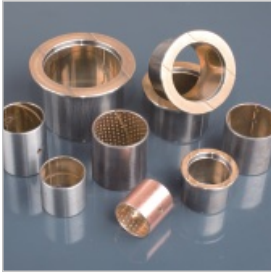

固体润滑剂  
Solid Lubricants

无铅铜合金烧结层  
CuSn8Ni Lead Free Bronze Alloy

低碳钢  
Low Carbon Steel

### 结构特性及用途 Structure Characteristics and Applications

以优质低碳钢为基础，表面烧结无铅铜合金材料和固体润滑剂的混合物，充分减小磨损因数，突破传统材料无法达到自我产生润滑源的生产工艺！相比普通双金属材料不但满足了无铅要求，而且具有更好的耐磨性，适合于边界润滑和流体润滑工况下的使用。

Based on high quality low carbon steel, sintering lead-free bronze alloy and solid lubricant on the surface, reduce the wear factor. The solid lubricant supplying the lubricant source when working. Compare with traditional bi-metal material, it not only meets the lead-free requirement, also can achieve excellent wear resistance, suitable for the condition of boundary lubrication and fluid lubrication.

### 物理机械性能 Physical and Mechanical Performance

性能指标 Performance Index		有关数据 Data	性能指标 Performance Index	有关数据 Data
最大承载压力P Max Load	静承载 Static	250 N/ mm <sup>2</sup>	合金硬度 Alloy Hardness	HB 60~ 100
	动承载 Dynamic	140 N/ mm <sup>2</sup>	使用温度 Temperature	-40℃~ 250℃
最大线速度V Linear Velocity		2.5 m/ s	摩擦系数 Friction Coefficient	0.05~ 0.12
最高PV值 Max PV value		2.8 N/ mm <sup>2</sup> · m/ s	导热系数 Thermal Conductivity	60 W/ ( m · k)
剪切强度 Shear Strength		170 N/ mm <sup>2</sup>	热膨胀系数 Coef. of thermal expansion	14 · 10 <sup>-6</sup> k <sup>-1</sup>

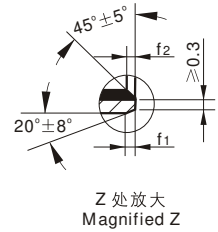
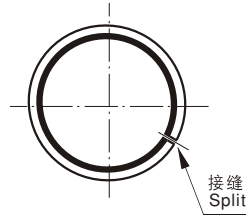
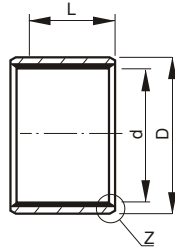
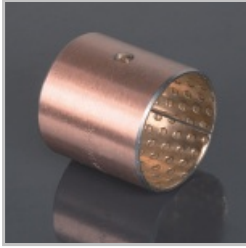

mm

d	D	壁厚 Wall Thickness	外径公差 O.D. Tolerance	内孔公差 I.D.(H8) Tolerance	配合座孔 H7 Housing bore	轴径 f <sub>7</sub> Shaft Dia.	L <sup>0</sup> <sub>-0.40</sub>								
							10	15	20	25	30	40	50		
10	12		12 <sup>+0.065</sup> <sub>+0.030</sub>	10 <sup>+0.022</sup>	12 <sup>+0.018</sup>	10 <sup>-0.013</sup> <sub>-0.028</sub>	1010	1015	1020						
12	14		14 <sup>+0.065</sup> <sub>+0.030</sub>	12 <sup>+0.027</sup>	14 <sup>+0.018</sup>	12 <sup>-0.016</sup> <sub>-0.034</sub>	1210	1215	1220						
14	16	1 <sup>-0.025</sup>	16 <sup>+0.065</sup> <sub>+0.030</sub>	14 <sup>+0.027</sup>	16 <sup>+0.018</sup>	14 <sup>-0.016</sup> <sub>-0.034</sub>	1410	1415	1420						
15	17		17 <sup>+0.065</sup> <sub>+0.030</sub>	15 <sup>+0.027</sup>	17 <sup>+0.018</sup>	15 <sup>-0.016</sup> <sub>-0.034</sub>	1510	1515	1520						
16	18		18 <sup>+0.075</sup> <sub>+0.035</sub>	16 <sup>+0.027</sup>	18 <sup>+0.018</sup>	16 <sup>-0.016</sup> <sub>-0.034</sub>	1610	1615	1620						
18	20		20 <sup>+0.075</sup> <sub>+0.035</sub>	18 <sup>+0.033</sup>	20 <sup>+0.021</sup>	18 <sup>-0.016</sup> <sub>-0.034</sub>	1810	1815	1820	1825					
20	23		23 <sup>+0.075</sup> <sub>+0.035</sub>	20 <sup>+0.033</sup>	23 <sup>+0.021</sup>	20 <sup>-0.020</sup> <sub>-0.041</sub>	2010	2015	2020	2025					
22	25	1.5 <sup>-0.030</sup>	25 <sup>+0.075</sup> <sub>+0.035</sub>	22 <sup>+0.033</sup>	25 <sup>+0.021</sup>	22 <sup>-0.020</sup> <sub>-0.041</sub>	2210	2215	2220	2225					
24	27		27 <sup>+0.075</sup> <sub>+0.035</sub>	24 <sup>+0.033</sup>	27 <sup>+0.021</sup>	24 <sup>-0.020</sup> <sub>-0.041</sub>	2410	2415	2420	2425	2430				
25	28		28 <sup>+0.075</sup> <sub>+0.035</sub>	25 <sup>+0.033</sup>	28 <sup>+0.021</sup>	25 <sup>-0.020</sup> <sub>-0.041</sub>		2515	2520	2525	2530				
26	30		30 <sup>+0.075</sup> <sub>+0.035</sub>	26 <sup>+0.033</sup>	30 <sup>+0.021</sup>	26 <sup>-0.020</sup> <sub>-0.041</sub>		2615	2620	2625	2630				
28	32		32 <sup>+0.085</sup> <sub>+0.045</sub>	28 <sup>+0.033</sup>	32 <sup>+0.025</sup>	28 <sup>-0.020</sup> <sub>-0.041</sub>		2815	2820	2825	2830	2840			
30	34		34 <sup>+0.085</sup> <sub>+0.045</sub>	30 <sup>+0.039</sup>	34 <sup>+0.025</sup>	30 <sup>-0.020</sup> <sub>-0.041</sub>		3015	3020	3025	3030	3040			
32	36	2 <sup>-0.035</sup>	36 <sup>+0.085</sup> <sub>+0.045</sub>	32 <sup>+0.039</sup>	36 <sup>+0.025</sup>	32 <sup>-0.025</sup> <sub>-0.050</sub>		3215	3220	3225	3230	3240			
35	39		39 <sup>+0.085</sup> <sub>+0.045</sub>	35 <sup>+0.039</sup>	39 <sup>+0.025</sup>	35 <sup>-0.025</sup> <sub>-0.050</sub>			3520	3525	3530	3540	3550		
38	42		42 <sup>+0.085</sup> <sub>+0.045</sub>	38 <sup>+0.039</sup>	42 <sup>+0.025</sup>	38 <sup>-0.025</sup> <sub>-0.050</sub>			3820	3825	3830	3840	3850		
40	44		44 <sup>+0.085</sup> <sub>+0.045</sub>	40 <sup>+0.039</sup>	44 <sup>+0.025</sup>	40 <sup>-0.025</sup> <sub>-0.050</sub>			4020	4025	4030	4040	4050		
45	50	2.5 <sup>-0.040</sup>	50 <sup>+0.085</sup> <sub>+0.045</sub>	45 <sup>+0.039</sup>	50 <sup>+0.025</sup>	45 <sup>-0.025</sup> <sub>-0.050</sub>			4520	4525	4530	4540	4550		

mm

d	D	壁厚 Wall Thickness	外径公差 O.D. Tolerance	内孔公差 I.D.(H8) Tolerance	配合座孔 H7 Housing bore	轴径 f7 Shaft Dia.	L <sup>0</sup> <sub>-0.40</sub>						
							30	40	50	60	80	90	100
50	55	2.5-0.040	55 <sup>+0.100</sup> <sub>+0.055</sub>	50 <sup>+0.039</sup>	55 <sup>+0.030</sup>	50 <sup>-0.025</sup> <sub>-0.050</sub>	5030	5040	5050				
55	60		60 <sup>+0.100</sup> <sub>+0.055</sub>	55 <sup>+0.046</sup>	60 <sup>+0.030</sup>	55 <sup>-0.030</sup> <sub>-0.060</sub>	5530	5540	5550	5560			
60	65		65 <sup>+0.100</sup> <sub>+0.055</sub>	60 <sup>+0.046</sup>	65 <sup>+0.030</sup>	60 <sup>-0.030</sup> <sub>-0.060</sub>	6030	6040	6050	6060			
65	70		70 <sup>+0.100</sup> <sub>+0.055</sub>	65 <sup>+0.046</sup>	70 <sup>+0.030</sup>	65 <sup>-0.030</sup> <sub>-0.060</sub>	6530	6540	6550	6560			
70	75	2.5-0.045	75 <sup>+0.100</sup> <sub>+0.055</sub>	70 <sup>+0.046</sup>	75 <sup>+0.030</sup>	70 <sup>-0.030</sup> <sub>-0.060</sub>	7030	7040	7050	7060	7080		
75	80		80 <sup>+0.100</sup> <sub>+0.055</sub>	75 <sup>+0.046</sup>	80 <sup>+0.030</sup>	75 <sup>-0.030</sup> <sub>-0.060</sub>	7530	7540	7550	7560			
80	85		85 <sup>+0.120</sup> <sub>+0.070</sub>	80 <sup>+0.046</sup>	85 <sup>+0.035</sup>	80 <sup>-0.030</sup> <sub>-0.060</sub>		8040	8050	8060	8080		
85	90		90 <sup>+0.120</sup> <sub>+0.070</sub>	85 <sup>+0.054</sup>	90 <sup>+0.035</sup>	85 <sup>-0.036</sup> <sub>-0.071</sub>		8540	8550	8560	8580		
90	95	2.5-0.050	95 <sup>+0.120</sup> <sub>+0.070</sub>	90 <sup>+0.054</sup>	95 <sup>+0.035</sup>	90 <sup>-0.036</sup> <sub>-0.071</sub>		90240	9050	9060	9080		
95	100		100 <sup>+0.120</sup> <sub>+0.070</sub>	95 <sup>+0.054</sup>	100 <sup>+0.035</sup>	95 <sup>-0.036</sup> <sub>-0.071</sub>			9550	9560	9580	9590	
100	105		105 <sup>+0.120</sup> <sub>+0.070</sub>	100 <sup>+0.054</sup>	105 <sup>+0.035</sup>	100 <sup>-0.036</sup> <sub>-0.071</sub>			10050	10060	10080	10090	
105	110		110 <sup>+0.120</sup> <sub>+0.070</sub>	105 <sup>+0.054</sup>	110 <sup>+0.035</sup>	105 <sup>-0.036</sup> <sub>-0.071</sub>			10550	10560	10580		
110	115	2.5-0.050	115 <sup>+0.120</sup> <sub>+0.070</sub>	110 <sup>+0.054</sup>	115 <sup>+0.035</sup>	110 <sup>-0.036</sup> <sub>-0.071</sub>			11050	11060	11080		
115	120		120 <sup>+0.120</sup> <sub>+0.070</sub>	115 <sup>+0.054</sup>	120 <sup>+0.035</sup>	115 <sup>-0.036</sup> <sub>-0.071</sub>			11550	11560	11580		
120	125		125 <sup>+0.170</sup> <sub>+0.100</sub>	120 <sup>+0.054</sup>	125 <sup>+0.040</sup>	120 <sup>-0.036</sup> <sub>-0.071</sub>			12050	12060	12080		
125	130		130 <sup>+0.170</sup> <sub>+0.100</sub>	125 <sup>+0.063</sup>	130 <sup>+0.040</sup>	125 <sup>-0.043</sup> <sub>-0.083</sub>			12550	12560	12580		125100
130	135	2.5-0.050	135 <sup>+0.170</sup> <sub>+0.100</sub>	130 <sup>+0.063</sup>	135 <sup>+0.040</sup>	130 <sup>-0.043</sup> <sub>-0.083</sub>			13050	13060	13080		130100
135	140		140 <sup>+0.170</sup> <sub>+0.100</sub>	135 <sup>+0.063</sup>	140 <sup>+0.040</sup>	135 <sup>-0.043</sup> <sub>-0.083</sub>			13550	13560	13580		135100
140	145		145 <sup>+0.170</sup> <sub>+0.100</sub>	140 <sup>+0.063</sup>	145 <sup>+0.040</sup>	140 <sup>-0.043</sup> <sub>-0.083</sub>				14060	14080		140100
145	150		150 <sup>+0.170</sup> <sub>+0.100</sub>	145 <sup>+0.063</sup>	150 <sup>+0.040</sup>	145 <sup>-0.043</sup> <sub>-0.083</sub>				14560	14580		145100
150	155	2.5-0.050	155 <sup>+0.170</sup> <sub>+0.100</sub>	150 <sup>+0.063</sup>	155 <sup>+0.040</sup>	150 <sup>-0.043</sup> <sub>-0.083</sub>				15060	15080	15090	
155	160		160 <sup>+0.170</sup> <sub>+0.100</sub>	155 <sup>+0.063</sup>	160 <sup>+0.040</sup>	155 <sup>-0.043</sup> <sub>-0.083</sub>				15560	15580	15590	
160	165		165 <sup>+0.170</sup> <sub>+0.100</sub>	160 <sup>+0.063</sup>	165 <sup>+0.040</sup>	160 <sup>-0.043</sup> <sub>-0.083</sub>				16060	16080		160100
165	170		170 <sup>+0.170</sup> <sub>+0.100</sub>	165 <sup>+0.063</sup>	170 <sup>+0.040</sup>	165 <sup>-0.043</sup> <sub>-0.083</sub>				16560	16580		165100
170	175	2.5-0.050	175 <sup>+0.170</sup> <sub>+0.100</sub>	170 <sup>+0.063</sup>	175 <sup>+0.040</sup>	170 <sup>-0.043</sup> <sub>-0.083</sub>				17060	17080		170100
175	180		180 <sup>+0.170</sup> <sub>+0.100</sub>	175 <sup>+0.063</sup>	180 <sup>+0.040</sup>	175 <sup>-0.043</sup> <sub>-0.083</sub>				17560	17560		175100

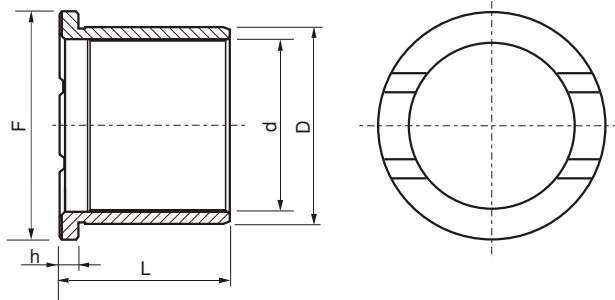
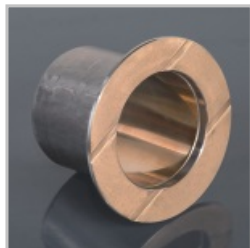

规格型号 Type	F	D	d	L	h
M4040	60	46	40	39.5	3.5
M4035	62	47	40	35	3.5
M4055	68	55	45	55	3.5
M5040	72	57	50	40	3.5
M5050	70	57	50	50	3.5
M5460	92	60.6	54	60	3.5
M6053	83	67	60	53	3.5
M6060	87	67	60	60	3.5
M6065	77	67	60	65	3.5
M6060	88	68	60	60	4.0
M6465	102.6	70.4	63.5	65	3.5
M6473	103	70.8	63.8	73	3.5
M6553	85	72	65	53	3.5
M6564	87	72	65	64	3.5
M6575	108	72	65	75	3.5
M7060	93	77	70	60	3.5
M7090	108	80	70	90	5.0
M7560	100	82	75	60	3.5
M8060	105	87	80	68	3.5
M8580	127	92	85	80	3.5
M85103	128	92.6	85	103.5	3.5
M89126	138	97.5	89.2	126.5	4.2
M95127	144	105	95	127	5.0

mm

按来图纸或来样制作



# VSB50 系列

## 固体润滑轴承

### SOLID-LUBRICANT-INLAID BEARING



- 设计合理，使用范围广；  
Properly and simply designer, widely used;
- 优越的耐药性和耐蚀性；  
Superior chemical resistance and corrosion resistance;
- 在高承载，低转速及往复运动、摇摆运动等固起动，停止频繁，而致使油膜无法生成的场所，可发挥其优越的性能。  
The superior functions can be brought into play under the occasion which oil film can not be formed for frequently start up, like high load, low rotating speed, cycle movement, reciprocating motion, swing motion and so on.
- 无油状态下可以使用；  
Being used without oil;
- 使用成本低，使产品成本更具竞争力；  
Low cost for usage, high competition.

# VSB50

## 铜基固体镶嵌轴承

### CAST BRONZE WITH GRAPHITE OILLESS BEARING

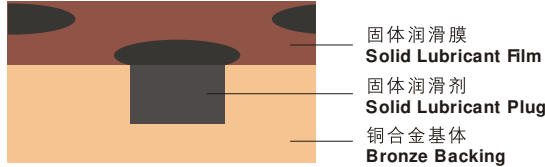

铜合金镶嵌式固体润滑剂自润滑轴承，结合了铜合金的耐磨性及固体润滑剂的自润滑性能，使其在使用过程中无需加油维护。产品被广泛用于高载、间歇性或摇摆运动，如汽车生产流水线、水轮机、水库工作/事故门、塑胶机械等。根据使用的工况，VKT可以提供各种类型的铜合金。

This material provides a maintenance free and low friction bearing solution, particularly for high load and intermittent oscillating motion. Solid lubricants within the bronze combine the strength of the bronze with the wear resistance of the graphite. Applications covered are automotive production lines, water industry, dam gates, plastic moulding machinery etc. Different types of bronze alloy can be offered according to the application.

标准 Standard	高力黄铜 CuZn25Al6 Fe3Mn3	锡青铜 CuSn5Zn5Pb5	铝青铜 CuAl10Fe5Ni5	锡青铜 CuSn12	特硬高力黄铜 CuZn25Al6 Fe3Mn3
密度 Density	8	8.9	7.9	8.9	8
硬度 Hardness	≥210	≥70	≥150	≥75	≥235
抗拉强度 N/mm <sup>2</sup> Tensile Strength	≥750	≥250	≥500	≥270	≥800
屈服强度 N/mm <sup>2</sup> Yield Strength	≥450	≥90	≥260	≥150	≥450
延伸率% Elongation	≥12	≥13	≥10	≥5	≥8
线胀系数 Coefficient of linear expansion	1.9 · 10 <sup>-5</sup> / °C	1.8 · 10 <sup>-5</sup> / °C	1.6 · 10 <sup>-5</sup> / °C	1.8 · 10 <sup>-5</sup> / °C	1.9 · 10 <sup>-5</sup> / °C
使用温度 Temp.	-40~ 300 °C	-40~ 400 °C	-40~ 400 °C	-40~ 400 °C	-40~ 300 °C
最大动承载 N/mm <sup>2</sup> Max Dynamic load	100	60	50	70	120
最大线速度(干)N/mm <sup>2</sup> Max Speed (Dry)	15	10	20	10	15
最大PV (润滑) Max PV (Lubrication) N/mm <sup>2</sup> · m/min	200	60	60	80	200
压缩永久变形量 300 N/mm <sup>2</sup>	< 0.01	< 0.05	< 0.04	< 0.05	< 0.005

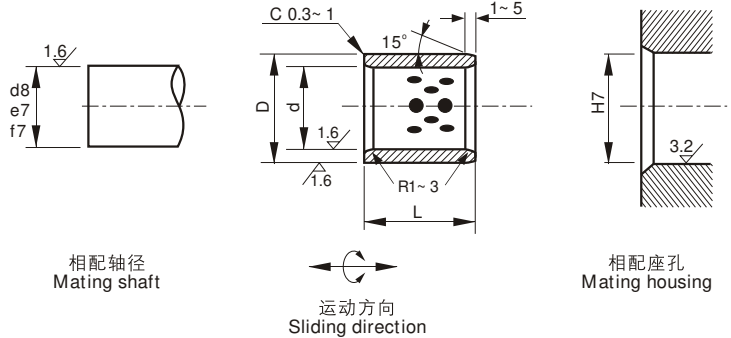

d	D	内孔公差 I.D. Tolerance F7	外径公差 O.D. Tolerance m6	L													
				10	12	15	16	20	25	30	35	40	50	60	70	80	100
10	14	10 <sup>+0.028</sup> <sub>+0.013</sub>	14 <sup>+0.018</sup> <sub>+0.007</sub>	101410	101412	101415		101420									
12	18	12 <sup>+0.034</sup> <sub>+0.016</sub>	18 <sup>+0.018</sup> <sub>+0.007</sub>	121810	121812	121815	121816	121820	121825	121830							
13	19	13 <sup>+0.034</sup> <sub>+0.016</sub>	19 <sup>+0.021</sup> <sub>+0.008</sub>	131910		131915	131916										
14	20	14 <sup>+0.034</sup> <sub>+0.016</sub>	20 <sup>+0.021</sup> <sub>+0.008</sub>	142010	142012	142015		142020	142025	142030							
15	21	15 <sup>+0.034</sup> <sub>+0.016</sub>	21 <sup>+0.021</sup> <sub>+0.008</sub>	152110	152112	152115	152116	152120	152125	152130							
16	22	16 <sup>+0.034</sup> <sub>+0.016</sub>	22 <sup>+0.021</sup> <sub>+0.008</sub>	162210	162212	162215	162216	162220	162225	162230	162235	162240					
18	24	18 <sup>+0.034</sup> <sub>+0.016</sub>	24 <sup>+0.021</sup> <sub>+0.008</sub>		182412	182415	182416	182410	182425	182430	182435	182440					
20	28	20 <sup>+0.041</sup> <sub>+0.020</sub>	28 <sup>+0.021</sup> <sub>+0.008</sub>	202810	202812	202815	202816	202820	202825	202830	202835	202840	202850				
22	32	22 <sup>+0.041</sup> <sub>+0.020</sub>	32 <sup>+0.025</sup> <sub>+0.009</sub>		223212	223215		223220	223225								
25	33	25 <sup>+0.041</sup> <sub>+0.020</sub>	33 <sup>+0.025</sup> <sub>+0.009</sub>		253312	253315	253316	253320	253325	253330	253535	253540	253550	253560			
30	38	30 <sup>+0.041</sup> <sub>+0.020</sub>	38 <sup>+0.025</sup> <sub>+0.009</sub>		303812	303815		303820	303825	303830	303835	303840	303850	303860			
35	45	35 <sup>+0.050</sup> <sub>+0.025</sub>	45 <sup>+0.025</sup> <sub>+0.009</sub>					354520	354525	354530	354535	354540	354550	354560			
40	50	40 <sup>+0.050</sup> <sub>+0.025</sub>	50 <sup>+0.025</sup> <sub>+0.009</sub>							405030	405035	405040	405050	405060	405070	405080	
45	55	45 <sup>+0.050</sup> <sub>+0.025</sub>	55 <sup>+0.030</sup> <sub>+0.011</sub>							455530	455535	455540	455550	455560			
50	60	50 <sup>+0.050</sup> <sub>+0.025</sub>	60 <sup>+0.030</sup> <sub>+0.011</sub>							506030	506035	506040	506050	506060	506070	506080	
50	62	50 <sup>+0.050</sup> <sub>+0.025</sub>	62 <sup>+0.030</sup> <sub>+0.011</sub>							506230	506235	506240	506250	506260	506270		
50	65	50 <sup>+0.050</sup> <sub>+0.025</sub>	65 <sup>+0.030</sup> <sub>+0.011</sub>							506530		506540	506550	506560	506570	506580	5065100
55	70	55 <sup>+0.060</sup> <sub>+0.030</sub>	70 <sup>+0.030</sup> <sub>+0.011</sub>									557040	557050	557060	557070		
60	74	60 <sup>+0.060</sup> <sub>+0.030</sub>	74 <sup>+0.030</sup> <sub>+0.011</sub>							607430	607435	607440	607450	607460	607470	607480	

mm

d	D	内孔公差 I.D. Tolerance F7	外径公差 O.D. Tolerance m6	L $\begin{matrix} -0.10 \\ -0.30 \end{matrix}$											
				30	35	40	50	60	70	80	100	120	130	140	150
60	75	$60^{+0.060}_{+0.030}$	$75^{+0.030}_{+0.011}$	607530	607535	607540	607550	607560	607570	607580	6075100				
63	75	$63^{+0.060}_{+0.030}$	$75^{+0.030}_{+0.011}$					637560	637570	637580					
65	80	$65^{+0.060}_{+0.030}$	$80^{+0.030}_{+0.011}$				658050	658060	658070	658080					
70	85	$70^{+0.060}_{+0.030}$	$85^{+0.035}_{+0.013}$		708535	708540	708550	708560	708570	708580	6080100				
70	90	$70^{+0.060}_{+0.030}$	$90^{+0.035}_{+0.013}$				709050	709060	709070	709080					
75	90	$75^{+0.060}_{+0.030}$	$90^{+0.035}_{+0.013}$					759060	759070	759080	7590100				
75	95	$75^{+0.060}_{+0.030}$	$95^{+0.035}_{+0.013}$					759560	759570	759580	7595100				
80	96	$80^{+0.060}_{+0.030}$	$96^{+0.035}_{+0.013}$			809640	809650	809660	809670	809680	8096100	8096120			
80	100	$80^{+0.060}_{+0.030}$	$100^{+0.035}_{+0.013}$			8010040	8010050	8010060	8010070	8010080	80100100	80100120		80100140	
90	110	$90^{+0.071}_{+0.036}$	$110^{+0.035}_{+0.013}$	9011030			9011050	9011060	9011070	9011080	90110100	90110120			
100	120	$100^{+0.071}_{+0.036}$	$120^{+0.035}_{+0.013}$					10012060	10012070	10012080	100120100	100120120		100120140	
110	130	$110^{+0.071}_{+0.036}$	$130^{+0.040}_{+0.015}$							11013080	110130100	110130120			
120	140	$120^{+0.071}_{+0.036}$	$140^{+0.040}_{+0.015}$							12014080	120140100	120140120		120140140	
125	145	$125^{+0.083}_{+0.043}$	$145^{+0.040}_{+0.015}$								125145100	125145120			
130	150	$130^{+0.083}_{+0.043}$	$150^{+0.040}_{+0.015}$								130150100		130150130		
140	160	$140^{+0.083}_{+0.043}$	$160^{+0.040}_{+0.015}$								140160100			140160140	
150	170	$150^{+0.083}_{+0.043}$	$170^{+0.040}_{+0.015}$								150170100				150170150
160	180	$160^{+0.083}_{+0.043}$	$180^{+0.040}_{+0.015}$								160180100				160180150

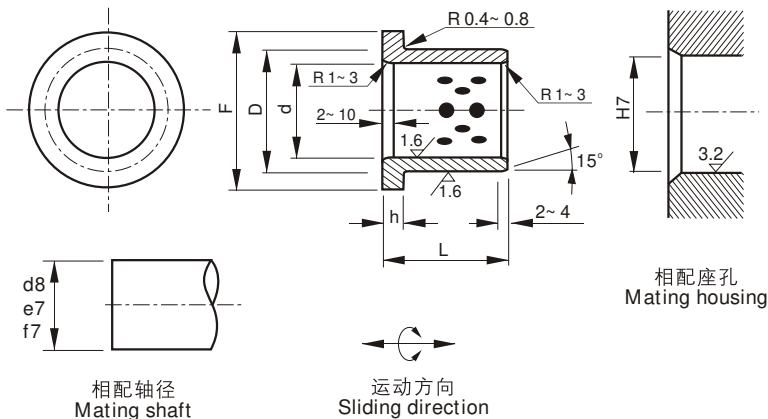

mm

d	D	内孔公差 I.D. Tolerance E7	外径公差 O.D. Tolerance r6	F	$h_{0.1}$	L $\begin{matrix} -0.10 \\ -0.30 \end{matrix}$										
						15	20	25	30	35	40	50	60	80	100	
10	14	$10^{+0.040}$ $+0.025$	$14^{+0.034}$ $+0.023$	22	2	101415	101420									
12	18	$12^{+0.050}$ $+0.032$	$18^{+0.034}$ $+0.023$	25		121815	121820									
13	19	$13^{+0.050}$ $+0.032$	$19^{+0.034}$ $+0.023$	26		131915	131920									
14	20	$14^{+0.050}$ $+0.032$	$20^{+0.041}$ $+0.028$	27	3	142015	142020									
15	21	$15^{+0.050}$ $+0.032$	$21^{+0.041}$ $+0.028$	28		152115	152120	152125	152130							
16	22	$16^{+0.050}$ $+0.032$	$22^{+0.041}$ $+0.028$	29		162215	162220	162225	162230							
20	30	$20^{+0.061}$ $+0.040$	$30^{+0.041}$ $+0.028$	40		203015	203020	203025	203030		203040					
25	35	$25^{+0.061}$ $+0.040$	$35^{+0.050}$ $+0.034$	45		253515	253520	253525	253530		253540					
30	40	$30^{+0.061}$ $+0.040$	$40^{+0.050}$ $+0.034$	50			304020	304025	304030	304035	304040	304050				
31.5	40	$31.5^{+0.075}$ $+0.050$	$40^{+0.050}$ $+0.034$	50			3154020			3154035						
35	45	$35^{+0.075}$ $+0.050$	$45^{+0.050}$ $+0.034$	60	5		354520		354030		354530	354550				
40	50	$40^{+0.075}$ $+0.050$	$50^{+0.050}$ $+0.034$	65			405020		405030		405030	405050				
45	55	$45^{+0.075}$ $+0.050$	$55^{+0.060}$ $+0.041$	70					455530		455530	455550	455560			
50	60	$50^{+0.075}$ $+0.050$	$60^{+0.060}$ $+0.041$	75					506030		506030	506050	506060			
55	65	$55^{+0.090}$ $+0.060$	$65^{+0.060}$ $+0.041$	80							556030		556560			
60	75	$60^{+0.090}$ $+0.060$	$75^{+0.062}$ $+0.043$	90							607530	607550		607580		
63	75	$63^{+0.090}$ $+0.060$	$75^{+0.062}$ $+0.043$	85	7.5									637580		
70	85	$70^{+0.090}$ $+0.060$	$85^{+0.073}$ $+0.051$	105							708550			708580		
75	90	$75^{+0.090}$ $+0.060$	$90^{+0.073}$ $+0.051$	110									759060			
80	100	$80^{+0.090}$ $+0.060$	$100^{+0.073}$ $+0.051$	120									8010060	8010080	80100100	
90	110	$90^{+0.107}$ $+0.072$	$110^{+0.076}$ $+0.054$	130									9010060	9011080		
100	120	$100^{+0.107}$ $+0.072$	$120^{+0.076}$ $+0.054$	150	10										10012080	100120100
120	140	$120^{+0.107}$ $+0.072$	$140^{+0.088}$ $+0.063$	170											12014080	120140100

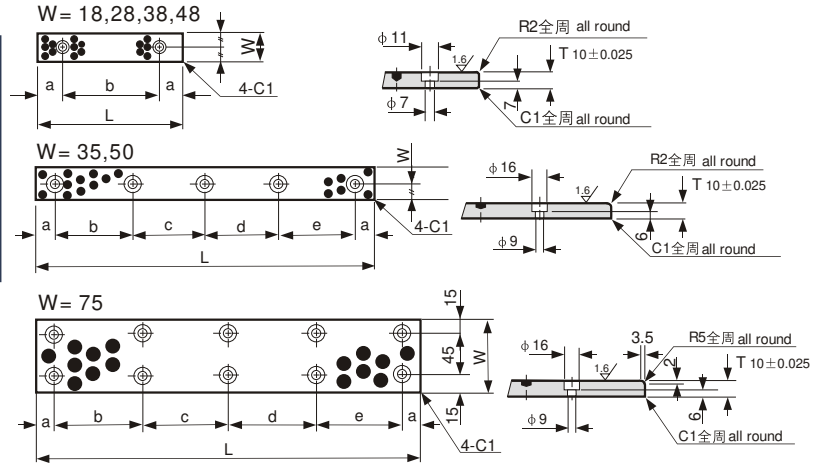

mm

规格型号 Type	W	L	a	b	c	d	e	平头螺钉 Flat Head Screw	孔数 No. of Holes
JSP-1875		75	15	45					
JSP-18100	18	100		50				M6	2
JSP-18125		125	25	75					
JSP-18150		150		100					
JSP-2875	28	75	15	45				M6	2
JSP-28100		100		50					
JSP-28125		125	25	75					
JSP-28150		150		100					
JSP-35100	35	100		60				M8	4
JSP-35150		150	20	55	55	55			
JSP-35200		200		70	70	70			
JSP-35250		250		65	65	65	65		5
JSP-35300		300		80	75	75	80		
JSP-35350		350							
JSP-3875	38	75	15	45				M6	2
JSP-38100		100		50					
JSP-38125		125	25	75					
JSP-38150		150		100					
JSP-4875	48	75	15	45				M8	4
JSP-48100		100		50					
JSP-48125		125	25	75					
JSP-48150		150		100					
JSP-50100	50	100		60				M8	4
JSP-50150		150	20	55	55	55			
JSP-50200		200		70	70	70			
JSP-50250		250		65	65	65	65		5
JSP-50300		300		90	90	90	90		
JSP-50400		400		110					
JSP-75150	75	150		80	80			M8	6
JSP-75200		200		105	105				
JSP-75250		250		85	90	85			
JSP-75300		300		120	120	120			8
JSP-75400		400		115	115	115	115		
JSP-75500		500							10

# VSB22 系列

## 青铜卷制轴承

### BRONZE WRAPPED BEARING



- 具有密度高、承载压力大、耐磨性能好、使用寿命长。  
High density, high load capacity, good property of anti-wear, long working time.
- 以取代传统的铸造铜套，可以缩小机械体积，降低成本。  
In place of traditional casting bronze bush, it is cheaper and more compact

## VSB22

### 青铜轴承

#### BRONZE WRAPPED BEARINGS



产品以青铜为基材,表面可按不同要求轧制半球形或菱形油穴、油槽。具有密度高、耐磨性能好、承载压力大、使用寿命长等优点,是取代传统铸造铜套的经济型轴承。广泛应用于农用机械、建筑机械、起重机械、汽车拖拉机底盘等部位。

The bearing is wrapped of a cold form able homogenous bronze, which will obtain exceptional material properties. The standard bearing is fitted with diamond shaped lubrication indents on the bearing surface. These indents serve as lubricant reservoirs to rapidly build up a lubrication film in the start movement and there with reduce the start friction. Typical application: widely applied in hoisting machines and other construction machines, automobiles, tractor, trucks, machines tools and some mineral engines.

密度 Density	8.9 g/cm <sup>3</sup>	硬度 Hardness	90~120 HB
抗压强度 Pressure resistance strength	470 N/mm <sup>2</sup>	延伸率 Elongation	40%
导热系数 Coefficient of heat conduction	60 W/m.K	材料名称 Alloy material	CuSn8P
线膨胀系数 Linear expansion coefficient	18.5x10 <sup>-6</sup> /K		

## VSB22 G

### 铜基固体润滑轴承

#### BRONZE WITH GRAPHITE WRAPPED BEARING



产品是以青铜材料为基体,表面嵌入固体润滑剂制作而成,使产品在起始运用阶段及过程中能有更低的摩擦系数,在短时间断油的情况下仍能保持良好的工作状态。广泛应用于汽机车离合器、工程机械等高载中速部位,也可在无油润滑的其它场合使用。

Feature: high load capacity, excellent wear resistance with lower friction, high level thermal conductivity, minimum overall dimensions, chemical resistance. Typical application: widely applied in hoisting machines and other construction machines, automobiles, tractors, trucks, machines tools and mineral engines.

密度 Density	8.3 g/cm <sup>3</sup>	硬度 Hardness	90~120 HB
抗压强度 Pressure resistance strength	470 N/mm <sup>2</sup>	延伸率 Elongation	40%
导热系数 Coefficient of heat conduction	58 W/m.K	材料名称 Alloy material	CuSn8P
线膨胀系数 Linear expansion coefficient	18.5x10 <sup>-6</sup> /K		



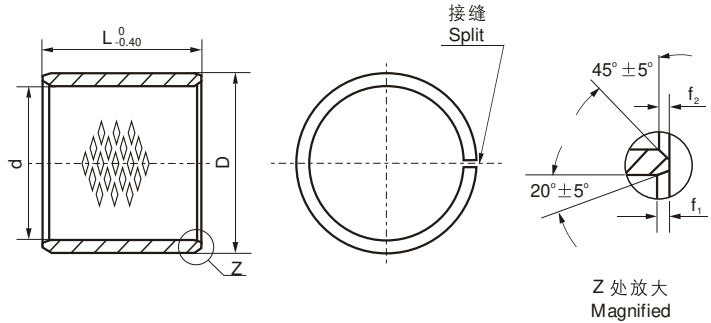

mm

压入H7座孔内径 Installed Bushing I.D.	外径 O.D.	f <sub>1</sub>	f <sub>2</sub>	L <sup>0</sup> <sub>-0.40</sub>													
				10	15	20	25	30	35	40	50	60	70	80			
10	12			1010	1015	1020											
12	14			1210	1215	1220											
14	16 <sup>+0.043</sup> <sub>0</sub>	0.5	0.3	1410	1415	1420	1425										
15	17			1510	1515	1520	1525										
16	18			1610	1615	1620	1625										
18	20			1810	1815	1820	1825										
20	23			2010	2015	2020	2025										
22	25	0.8	0.4	2210	2215	2220	2225										
24	27 <sup>+0.075</sup> <sub>+0.035</sub>				2415	2420	2425	2430									
25	28 <sup>+0.052</sup> <sub>0</sub>				2515	2520	2525	2530									
28	32				2815	2820	2825	2830									
30	34				3015	3020	3025	3030	3035	3040							
32	36	1.0	0.6		3215	3220	3225	3230	3235	3240							
35	39 <sup>+0.085</sup> <sub>+0.045</sub>				3515	3520	3525	3530	3535	3540							
40	44 <sup>+0.062</sup> <sub>0</sub>					4020	4025	4030	4035	4040	4050						
45	50					4520	4525	4530	4535	4540	4550						
50	55					5020	5025	5030	5035	5040	5050	5060					
55	60					5520	5525	5530	5535	5540	5550	5560					
60	65	1.2	0.8				6025	6030	6035	6040	6050	6060	6070				
65	70 <sup>+0.100</sup> <sub>+0.055</sub>							6530	6535	6540	6550	6560	6570				
70	75 <sup>+0.074</sup> <sub>0</sub>							7030	7035	7040	7050	7060	7070	7080			
75	80							7530	7535	7540	7550	7560	7570	7580			
80	85 <sup>+0.120</sup> <sub>+0.070</sub>	1.4						8030	8035	8040	8050	8060	8070	8080			

mm

压入H7座孔内径 Installed Bushing I.D.		外径 O.D.		f <sub>1</sub>	f <sub>2</sub>	L <sup>0</sup> <sub>-0.40</sub>								
						30	35	40	50	60	70	80	90	100
85		90				8530	8535	8540	8550	8560	8570	8580	8590	85100
90		95				9030	9035	9040	9050	9060	9070	9080	9090	90100
95		100						9540	9550	9560	9570	9580	9590	95100
100	+0.087 0	105	+0.120 +0.070						10050	10060	10070	10080	10090	100100
105		110								10550	10560	10570	10580	10590
110		115							11050	11060	11070	11080	11090	110100
115		120							11550	11560	11570	11580	11590	115100
120		125								12060	12070	12080	12090	120100
125		130								12560	12570	12580	12590	125100
130		135								13060	13070	13080	13090	130100
135		140								13560	13570	13580	13590	135100
140		145								14060	14070	14080	14090	140100
145		150								14560	14570	14580	14590	145100
150	+0.1 0	155	+0.170 +0.100							15060	15070	15080	15090	150100
155		160									15560	15570	15580	15590
160		165		1.4	0.8					16060	16070	16080	16090	160100
165		170								16560	16570	16580	16590	165100
170		175								17060	17070	17080	17090	170100
175		180								17560	17570	17580	17590	175100
180		185								18060	18070	18080	18090	180100
185		190								18560	18570	18580	18590	185100
190		195								19060	19070	19080	19090	190100
195		200								19560	19570	19580	19590	195100
200		205	+0.210 +0.130							20060	20070	20080	20090	200100
205	+0.115 0	210									20560	20570	20580	20590
215		220									21560	21570	21580	21590
225		230								22560	22570	22580	22590	225100
230		235								23060	23070	23080	23090	230100
240		245								24060	24070	24080	24090	240100
250		255								25060	25070	25080	25090	250100
260		265								26060	26070	26080	26090	260100
270		275	+0.260 +0.170							27060	27070	27080	27090	270100
280	+0.13 0	285									28060	28070	28080	28090
290		295									29060	29070	29080	29090
300		305								30060	30070	30080	30090	300100

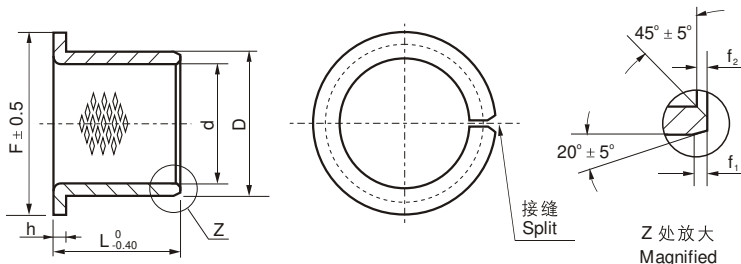

mm

压入H7座孔内径 Installed Bushing I.D.	外径 O.D.	F	f <sub>1</sub>	f <sub>2</sub>	L <sup>0</sup> <sub>-0.40</sub>													
					15	20	25	30	35	40	50	60	70	80	90			
25	28	35	0.8	0.4	2515	2520	2525											
30	34	45				3020	3025	3030										
35	39	50	1.0	0.6		3520	3525	3530	3535									
40	44	55					4025	4030	4035	4040								
45	50	60						4530	4535	4540	4550							
50	55	65						5030	5035	5040	5050							
55	60	70						5530	5535	5540	5550							
60	65	75	1.2	0.8				6030	6035	6040	6050	6060						
65	70	80						6530	6535	6540	6550	6560						
70	75	85							7035	7040	7050	7060	7070					
75	80	90							7535	7540	7550	7560	7570					
80	85	100							8035	8040	8050	8060	8070	8080				
90	95	110									9050	9060	9070	9080	9090			
100	105	120									10050	10060	10070	10080	10090			
110	115	130									11050	11060	11070	11080	11090			
120	125	140									12050	12060	12070	12080	12090			
130	135	155										13060	13070	13080	13090			
140	145	165										14060	14070	14080	14090			
150	155	180										15060	15070	15080	15090			
160	165	190										16060	16070	16080	16090			
170	175	200	1.4	0.8								17060	17070	17080	17090			
180	185	215										18060	18070	18080	18090			
190	195	225										19060	19070	19080	19090			
200	205	235										20060	20070	20080	20090			
225	230	260										22560	22570	22580	22590			
250	255	290										25060	25070	25080	25090			
265	270	305										26560	26570	26580	26590			
285	290	325										28560	28570	28580	28590			
300	305	340										30060	30070	30080	30090			

## ► 轴承选择 Bearing Selection

VIIPLUS 公司根据不同的工况条件设计了不同的轴承材料。一般来说，用户在使用和设计时应当根据轴承的使用温度、承载面压、线速度、耐磨性能要求、运动类型、安装情况、轴承成本等各方面因素综合考虑。

VIIPLUS have developed kinds of bearing material According to difference work condition .The user can select the material the material base on bearing work environment, load, speed, wear resistance resistance request, moving method, etc.

## ► 面压计算 Bearing Load:

► 直套、翻边产品 Cylindrical bushes, flangebushes

$$P = \frac{F}{d \times L} \quad (N/mm^2)$$

F= 轴承承载植 Load (N)  
d= 轴径 Shaft (mm)  
L= 轴承长度 Bearing Length (mm)

► 止推垫片 Thrust washer

$$P = \frac{4F}{\pi(D^2 - d^2)} \quad (N/mm^2)$$

F= 垫片承载植 Load (N)  
d= 垫片外径 Shaft (mm)  
L= 垫片内径 Bearing Length (mm)

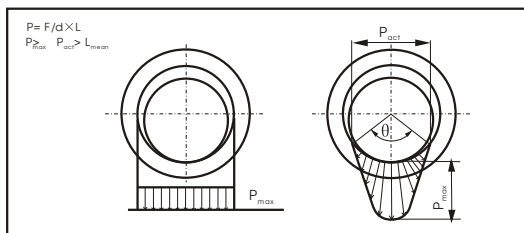

由于受配合间隙、材料强度、轴承倒角、内部油槽等原因的影响，轴承的真正承载面压 (P) 会大于理论计算值 (P)  
As the factor of clearance, bushes chamfer, oil groove etc., The actually load(P) is higher than theory of calculation(P)

## ► 线速度计算 Bearing Load:

► 旋转运动 Rotating motion

$$V = \frac{\pi \times d \times n}{1000 \times 60} \quad (m/s^2)$$

d= 轴径 Shaft (mm)  
n= 转数/分 Rpm

► 摇摆运动 Oscillating motion

$$V = \frac{\pi \times d \times C \times \theta}{1000 \times 360 \times 60} \quad (m/s^2)$$

d= 轴径 Shaft (mm)  
C= 摇摆频率 frequency (次数/分)  
 $\theta$  = 摇摆角度 Oscillating angle

► 往复运动 Rotating motion

$$V = \frac{2s \times c}{60} \quad (m/s)$$

s= 行程长度 Stoke distance (m)  
c= 往复频率 frequency (次数/分)

## ► PV值计算 PV = P × V ( N/mm<sup>2</sup> × m/s )

PV是指轴承在一定的承载和线速度条件下的乘积之和，PV值与轴承的使用寿命成反比例关系。因此建议设计时尽量使用比较低的安全的PV值，以确保轴承会有更长的寿命。同时在选择材料时也要注意不能超过承载、线速度、使用温度等极限值，并尽可能地小。

PV is the product of the specific bearing load P and the sliding speed V which is very important design date. We recommend design lower PV value will leads to longer service life. Also don't exceed the max. of material load, speed, temp. and lower if possible.

## ► 安装注意事项 Installation:

装配前应确保座孔内表面光洁无异物以免装配时划伤。装配时应采用芯轴慢慢压入，禁止直接敲打轴套以免产生变形。座孔设计时如需采用易变形材料如铝合金或座孔壁厚较薄时，请予以说明，以免压装时使座孔变形。为了使装配更简单且不会破坏耐磨层，轴的端面必须有倒角圆滑过度，轴的材质建议为轴承钢表面淬火处理 HRC45，表面粗糙度为 Ra1.6~1.8，表面也可镀硬铬，有可能的话，请在轴表面涂上油脂以缩短轴套走合期。非卷制类厚壁轴承建议使用液氮冷冻。

The bearing, housing and fitting tools must be kept clean during fitting. Please give special notice to us if you adopt the soft material for housing produce. To make fitting easy, the shaft ends should be chamfered.

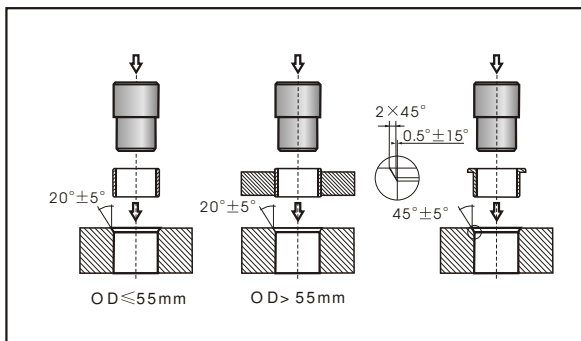

► 轴承检验 Bearing Checking

测量对象 Checking Items	测量方法 Checking Methods	测量工具 Checking Equipments
法兰外径 Flanged O.D.	用游标卡尺测量 Measure with Vernier Calipers	游标卡尺 Vernier Calipers
法兰高度 Flanged Height	用游标卡尺测量 Measure with Vernier Calipers	游标卡尺 Vernier Calipers
外径 O.D.	在离端面5-10mm处,圆面方向均分2-4点测量 Measure at 2-4 evenly distributed points on the outside surface ,with in 5-10mm away the end face.	外径千分尺 Micrometer for O.D. Checking
内径 I.D.	在离端面5-10mm内,圆面方向均分2-4点测量 Measure at 2-4 evenly distributed points on the inside surface ,with in 5-10mm away the end face.	三爪内测千分尺; 内径量表 Three-tongs Micrometer for ID Checking,
	若有特殊要求, 内径 < 80mm时可用塞规检测内径。要求通塞规通过, 通过力 < 250N, 止塞规止住。(不允许止规进入轴套) If particularly required, when inside diameter 80mm is smaller than 80mm, it can be measured by a plug gauge. It requires that, with a press force no more than 250N, the 'GO' plug gauge could go though the bearing while the 'NOGO' gauge can not go though. (It is not allowed to force the 'NO GO' plug gauge go though the bearing)	塞规 Plug Gauge
高度Height	沿圆周方向均分三点测量 Measure at three evenly distributed points across the circle.	游标卡尺 Vernier Calipers
外径 O.D.	用环规检验, 要求轴套在环规中通过, 通过力 < 25kg, 在止规中止住。(允许轴套进入止规1/3) Check with ring gauges. With a force equal to or less than 250N, the bearing can go though the 'GO' ring gauge, while cannot go though the 'NOGO' ring gauge. (Allow 1/3of the bush go into the 'NOGO' ring gauge)	环规; 止规 'GO'Ring Gauge, 'NOGO' Ring Gauge
壁厚 Wall Thickness	沿圆周方向均分三点测量 Measure at three evenly distributed points across the circle.	壁厚千分尺 Micrometer for Wall Thickness Checking
高度 Height	沿圆周方向均分三点测量 Measure at three evenly distributed points across the circle.	游标卡尺 Vernier Calipers

▶ 滑块垫片检验  
Checking for Gliding Plates and Washers

测量对象 Checking Items	测量方法 Checking Methods	测量工具 Checking Equipments
长度, 宽度 Length, Width	用游标卡尺测量 Measure with Vernier Calipers	游标卡尺 Vernier Calipers
	对环形垫片测量内外径。若是两个半圈, 则需将垫片拼接成圆, 用游标卡尺测量内、外径尺寸  The inner and outer diameters of the annular washer are measured. If the thrust are two half-ring, we need joint to measure the inner diameter.	游标卡尺 Vernier Calipers
厚度 Thickness	用游标卡尺测量 Measure with Vernier Calipers	壁厚千分尺 Micrometer for Wall Thickness Checking  游标卡尺 Vernier Calipers
孔径 Bore Diameter	内径千分尺 Measure with micrometer for I.D. checking	内径千分尺 Micrometer for I.D. Checking  游标卡尺 Vernier Calipers
孔距 Bore Gap	用游标卡尺测量 Measure with Vernier Calipers	游标卡尺 Vernier Calipers

Your partner for Self-lubricating

Bearing Application

# viiplus

[www.viiplus.com](http://www.viiplus.com)

IS YOUR BEST CHOICE

SLIDING BEARINGS SPECIALIST



**VIPLUS INTERNATIONAL**

电话 (TEL): +86 573 84662 058

邮箱 (E-mail): [viiplus@viiplus.com](mailto:viiplus@viiplus.com)

网址 (Website): [www.viiplus.com](http://www.viiplus.com)

地址：浙江省嘉兴县嘉善大道创业路 555号，产业园区  
Add: No.555 Chuangye Road, Industrial Zone, Jiashan, Zhejiang, China